

For measuring immediately downstream of the compressor in moist air up to +180 °C

FIELD OF APPLICATION:

- Measurement immediately downstream of the compressor
- Measurement at high temperatures
- Measurement of fast processes



Benefits at a glance:

- Particularly suitable for extremely high flow rates
- Extremely fast response time: 100 ms
- Flow, total consumption, temperature and pressure
- Measurement at high temperatures, max. temperature 180 °C
- Measurement in various gases by selecting the gas type, on request
- Can be used in pipes from DN 20 to DN 500
- Installation via 1/2" ball valve under pressure
- RS 485 interface (Modbus-RTU), 4...20 mA, pulse output as standard

Typical applications:

- Measurement of the capacity of compressors
- Compressed air audits
- Efficiency measurement of compressed air systems

Installation requirements:

- After functioning water separator
- In horizontal lines (recommended) or in risers

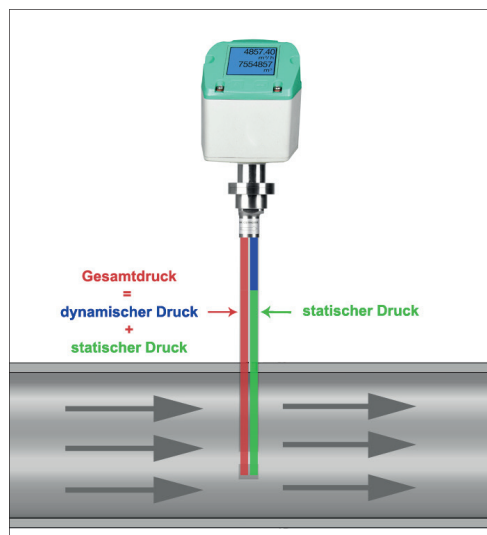

The integrated, precise differential pressure sensor measures the differential pressure/dynamic pressure at the sensor tip. The pressure depends on the respective gas velocity. The flow is therefore easy to determine by means of the pipe diameter.

The additional measurement of temperature and absolute pressure and calculation of the relevant density means that measuring can be carried out for various gases, a wide variety of temperatures and pressures.

TECHNICAL DATA VD 500

Measuring range:	up to 224 m/s / 600 m/s
Measured medium:	Air, non-aggressive gases
Accuracy: (m.v.: of meas. value) (f.s.: of full scale)	± 1.5% of m.v. ± 0.3% of f.s. (20...224 m/s) ± 1.5% of m.v. (> 224 m/s)
Measuring principle:	Differential pressure
Measuring span:	1:10
Response time:	t 99: < 1 sec.
Temperature of the medium:	-30 °...+180 °C
Operating pressure:	Max. 20 bar
Ambient temperature:	-30 °...+70 °C
Screw-in thread:	G 1/2", ISO 228
Power supply:	18...36 VDC, 5 W
Signal outputs:	As standard: RS 485 (Modbus-RTU), 4...20 mA, pulse Optional: Ethernet Interface (PoE), M-Bus

Example order code VD 500:

0690 5001_A1_B1_C1_D1_E1_F1_G1_K1

Measuring range	
A1	224 m/s
A2	600 m/s
Screw-in thread	
B1	G 1/2"
B2	G 1/2" NPT male thread
Installation length / shaft length	
C1	220 mm
C2	400 mm
Display	
D1	with integrated display
Signal outputs / bus connection option	
E1	1x 4...20 mA analogue output (electrically not isolated), pulse output, RS 485 (Modbus-RTU)
E2	Ethernet interface (Modbus/TCP), 1 x 4...20 mA analogue output (not electrically isolated), RS 485 (Modbus-RTU)
E3	Ethernet interface PoE (Power over Ethernet) (Modbus/TCP), 1 x 4...20 mA analogue output (not electrically isolated), RS 485 (Modbus-RTU)
E4	M-Bus, 1 x 4...20 mA analogue output (not electrically isolated), RS 485 (Modbus-RTU)
Reference standard	
G1	20 °C, 1000 mbar
G2	0 °C, 1013.25 mbar
G3	15 °C, 981 mbar
G4	15 °C, 1013.25 mbar
Gas type	
K1	Compressed air
K90	Additional gas on request

Simple installation and removal under pressure

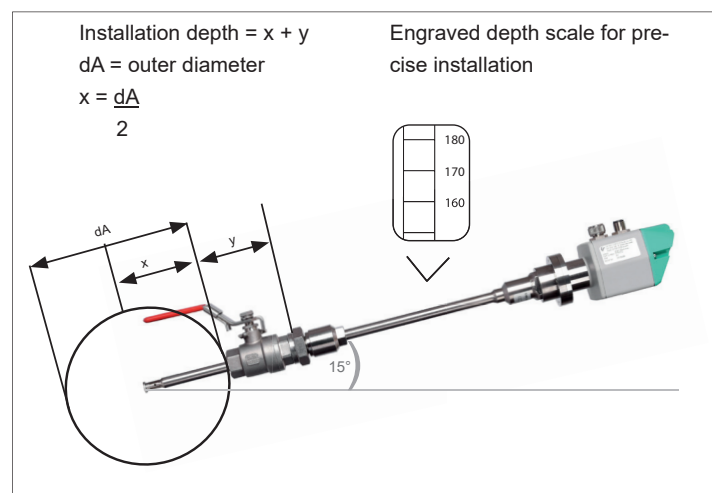

DESCRIPTION	ORDER NO.
VD 500 flow sensor for wet compressed air	0690 5001 + Order code A...K_
Accessories:	
ISO calibration certificate	3200 0001
High-pressure protection	0530 1117

For further accessories refer to pages 88 to 92

Flow measuring ranges VD 500 for compressed air at a typical 7 bar (abs) and 50 °C (ISO 1217:1000 mbar, 20 °C)				
Inside diameter of pipe			VD 500 20 ... 224 m/s	
Inch	mm	DN	Measuring range initial values and full scale m³/h (cfm)	
3/4"	21.7	DN 20	19 ... 215	11 ... 127
1"	27.3	DN 25	32 ... 357	19 ... 210
1 1/4"	36.0	DN 32	57 ... 644	34 ... 379
1 1/2"	41.9	DN 40	79 ... 886	47 ... 522
2"	53.1	DN 50	130 ... 1450	76 ... 853
2 1/2"	68.9	DN 65	222 ... 2484	131 ... 1462
3"	80.9	DN 80	307 ... 3440	181 ... 2025
4"	110.0	DN 100	571 ... 6391	336 ... 3762
5"	133.7	DN 125	844 ... 9453	497 ... 5564
6"	159.3	DN 150	1200 ... 13436	706 ... 7908
8"	200.0	DN 200	1896 ... 21230	1116 ... 12495
10"	250.0	DN 250	2966 ... 33211	1746 ... 19547
12"	300.0	DN 300	4276 ... 47881	2517 ... 28182