



# TKD DN 10÷50

FIP has developed a TKD DUAL BLOCK® ball valve to introduce a high reference standard in thermoplastic valve design. TKD is a True Union diverting and mixing ball valve that meets the most stringent needs required in industrial applications.



## DUAL BLOCK® 3-WAY BALL VALVE

- Connection system for solvent weld, threaded and flanged joints
- Patented **SEAT STOP®** ball carrier system that lets you micro-adjust ball seats and minimise axial force effects
- Easy radial dismounting allowing quick replacement of O-rings and ball seats without any need for tools
- **PN16 True Union valve body** made for rigid PVC-U injection moulding equipped with built-in bores for actuation. ISO 9393 compliant test requirements
- Option of dismounting downstream pipes with the valve in the closed position
- High surface finish stem with double O-Ring and double connection key to the ball, equipped with **visual ball position indicator** for correct handle installation
- **Integrated bracket** for valve anchoring
- Possibility of installing pneumatic and/or electric actuators thanks to the robust anchor tower for easy and quick automation using the **Power Quick module** (optional)
- Possibility to have handle with integrated LSQT limit micro switch, even as a retrofit in existing installations

Technical specifications	
<b>Construction</b>	3-way True Union ball valve with locked carrier and union nuts
<b>Size range</b>	DN 10 ÷ 50
<b>Nominal pressure</b>	PN 16 with water at 20 °C
<b>Temperature range</b>	0 °C ÷ 60 °C
<b>Coupling standards</b>	<b>Solvent welding:</b> EN ISO 1452, EN ISO 15493, BS 4346-1, DIN 8063, NF T54-028, ASTM D 2467, JIS K 6743. Pipe coupling capacity according to EN ISO 1452, EN ISO 15493, DIN 8062, NF T54-016, ASTM D 1785, JIS K 6741 <b>Thread:</b> ISO 228-1, DIN 2999, ASTM D 2467 JIS B 0203.
<b>Reference standards</b>	<b>Construction criteria:</b> EN ISO 16135, EN ISO 1452, EN ISO 15493 <b>Test methods and requirements:</b> ISO 9393 <b>Installation criteria:</b> DVS 2204, DVS 2221, UNI 11242 <b>Actuator couplings:</b> ISO 5211
<b>Valve material</b>	PVC-U
<b>Seal material</b>	EPDM, FKM (standard size O-Ring); PTFE (ball seats)
<b>Control options</b>	Manual control; electric actuator; pneumatic actuator

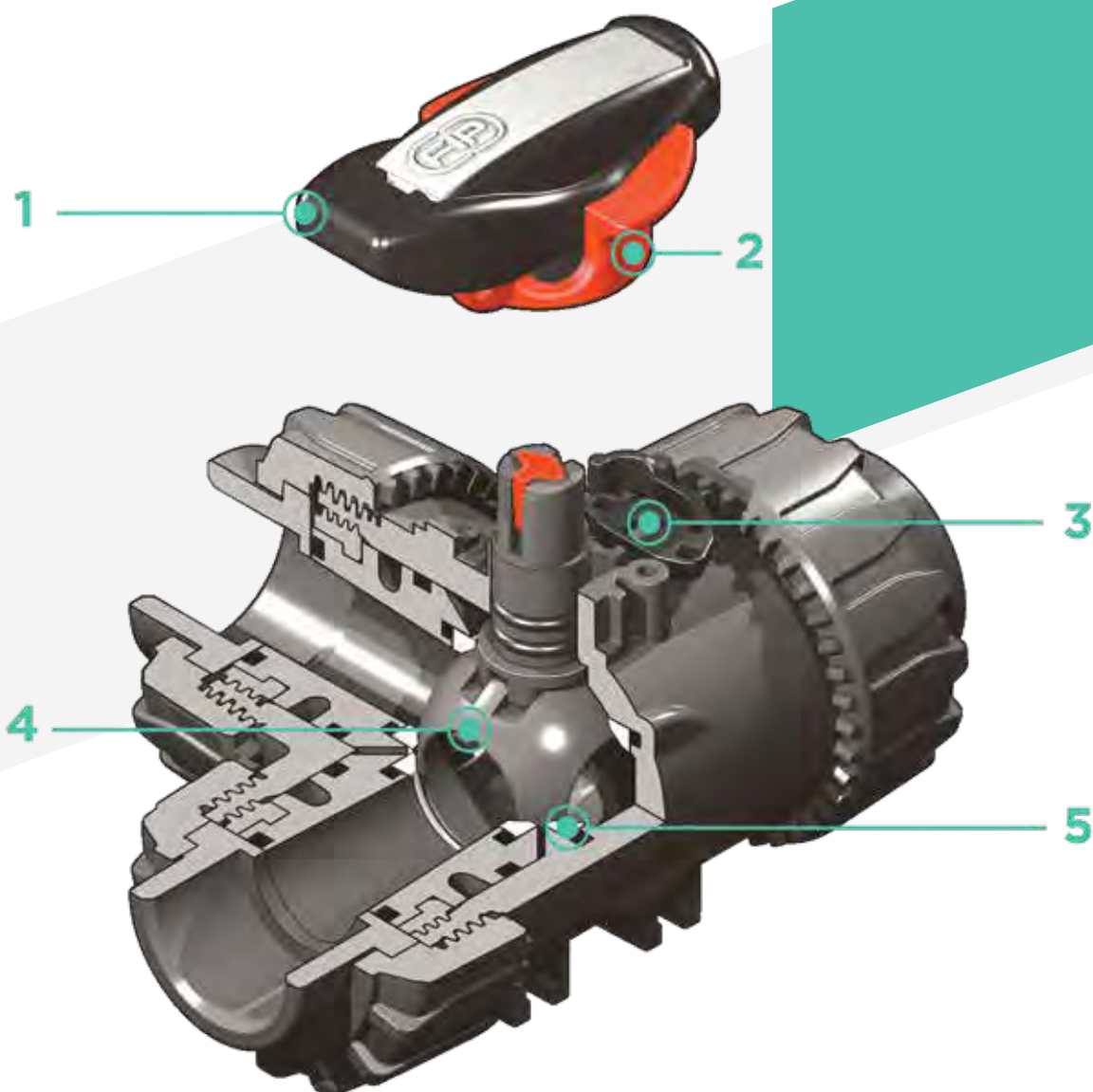

**1** Ergonomic HIPVC handle equipped with removable tool to adjust the ball seat carrier. Possibility of installing the **LTKD stroke limiter** (available as an accessory) that permits ball and handle rotation only for set opening and closing angles at 90° or 180°

**2** **Handle lock 0°- 90° SHKD** (available as an accessory) ergonomically operable during service and padlockable

**3** **DUAL BLOCK®** patented lock system that ensures union nut tightening hold even in severe conditions such as vibrations or heat dilation

**4** **Ball shutter** high surface finish with floating type full passage with **T or L port**

**5** **4 PTFE ball seat system** that compensates axial force guaranteeing optimal manageability and long working life

# TECHNICAL DATA

## PRESSURE VARIATION ACCORDING TO TEMPERATURE

For water and harmless fluids to which the material is classified as CHEMICALLY RESISTANT. In other cases, a reduction of the nominal PN pressure is required (25 years with safety factor).



## PRESSURE DROP GRAPH AND WORK POSITIONS

A - T-port ball valve:  
0° - Mixing

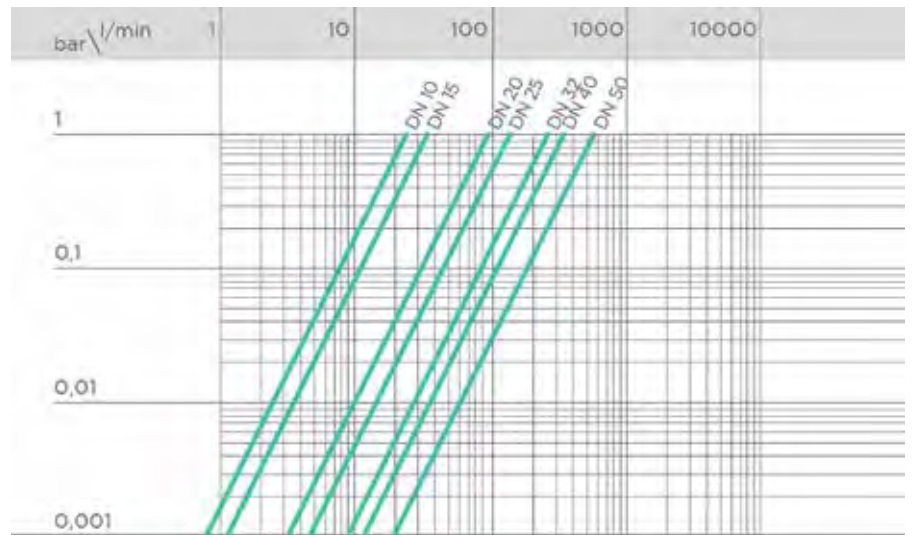
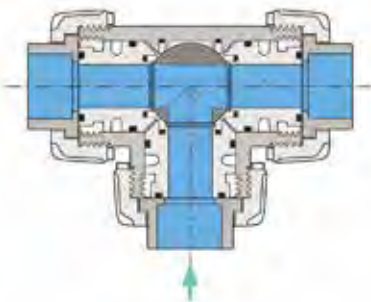

B - T-port ball valve:  
90° - Diverting

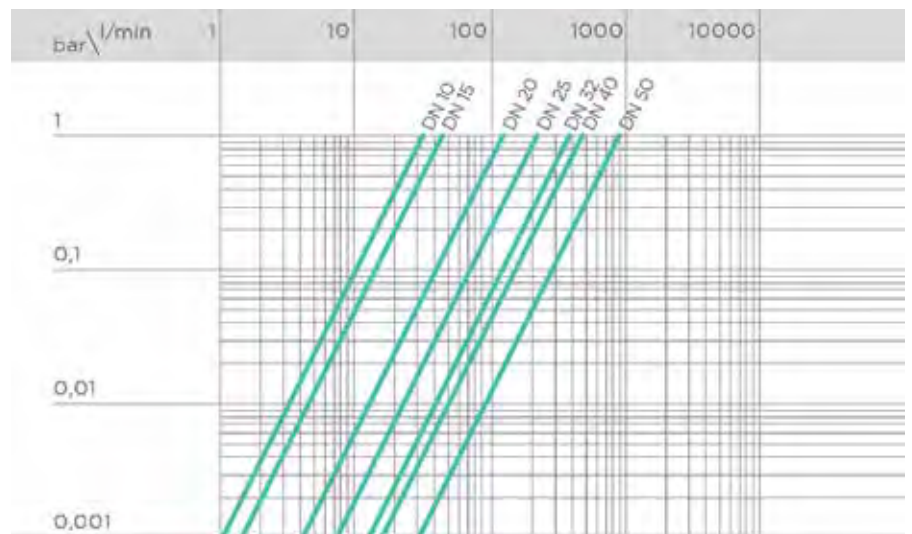
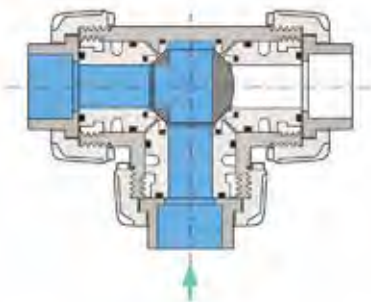

C - T-port ball valve:  
180° - Branch closed/direct flow

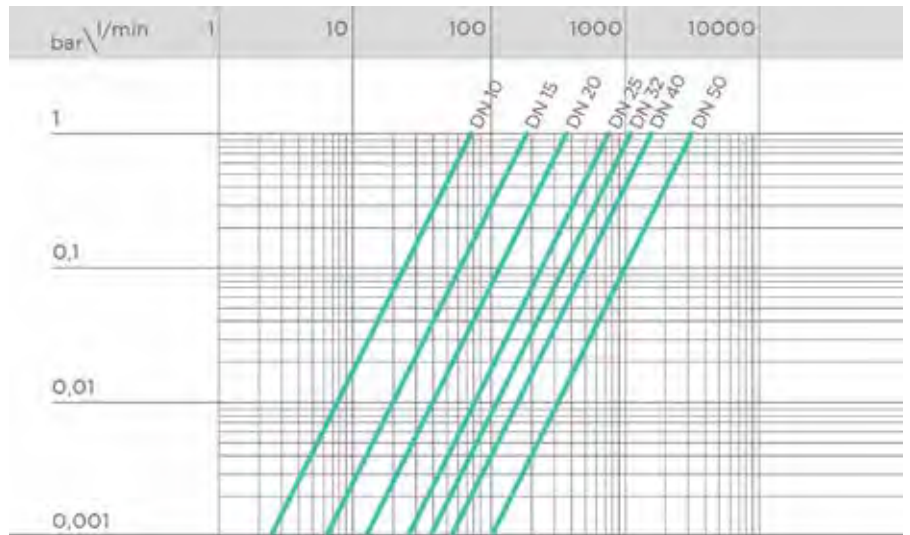
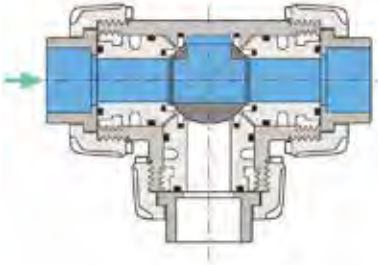

D - T-port ball valve:  
270° - Diverting

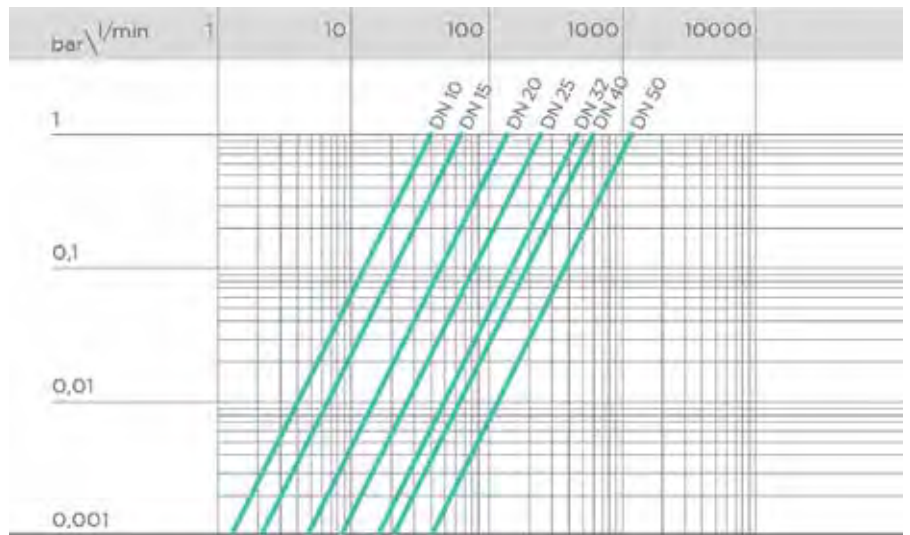
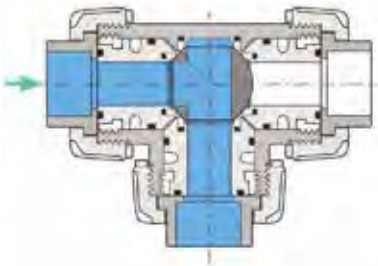

E - L-port ball valve:  
0°/270° - Diverting

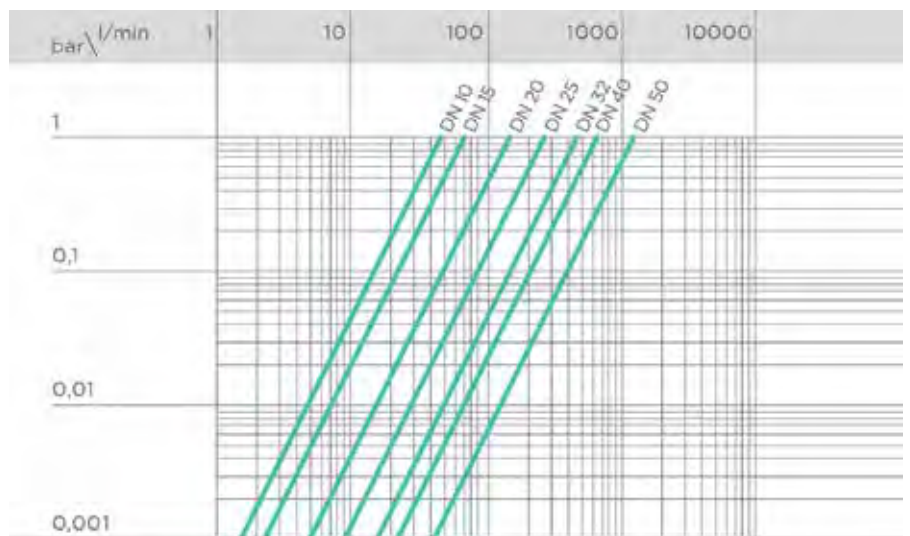
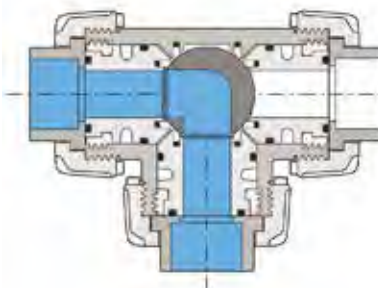

## K<sub>v</sub>100 FLOW COEFFICIENT

The K<sub>v</sub>100 flow coefficient is the Q flow rate of litres per minute of water at a temperature of 20°C that will generate Δp= 1 bar pressure drop at a certain valve position. The Kv100 values shown in the table are calculated with the valve completely open.

DN	10	15	20	25	32	40	50
A	25	35	95	140	270	330	620
B	37	55	135	205	390	475	900
C	78	195	380	760	1050	1700	3200
D	40	65	145	245	460	600	1200
E	48	73	150	265	475	620	1220

## OPERATING TORQUE AT MAXIMUM WORKING PRESSURE



# DIMENSIONS

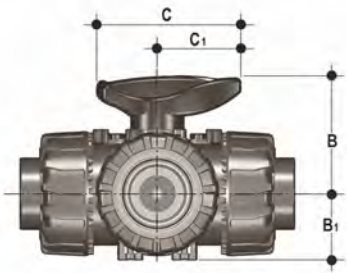

Dimensions shared by all versions

d	DN	B	B <sub>1</sub>	C	C <sub>1</sub>
16	10	54	29	67	40
20	15	54	29	67	40
25	20	65	34,5	85	49
32	25	69,5	39	85	49
40	32	82,5	46	108	64
50	40	89	52	108	64
63	50	108	62	134	76

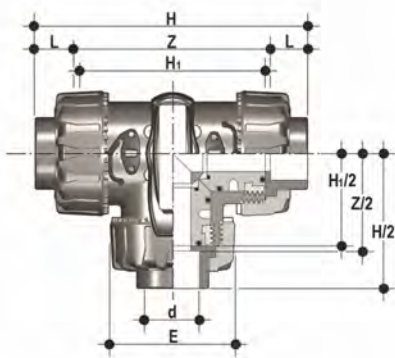

## TKDIV

DUAL BLOCK® 3-way ball valve with metric plain socket ends for solvent welding, T bore.

d	DN	PN	E	H	H <sub>1</sub>	L	Z	g	EPDM code	FKM code
16	10	16	54	118	80	14	90	310	TKDIV016E	TKDIV016F
20	15	16	54	118	80	16	86	310	TKDIV020E	TKDIV020F
25	20	16	65	145	100	19	107	550	TKDIV025E	TKDIV025F
32	25	16	73	160	110	22	116	790	TKDIV032E	TKDIV032F
40	32	16	86	188.5	131	26	136.5	1275	TKDIV040E	TKDIV040F
50	40	16	98	219	148	31	157	1660	TKDIV050E	TKDIV050F
63	50	16	122	266.5	179	38	190.5	2800	TKDIV063E	TKDIV063F

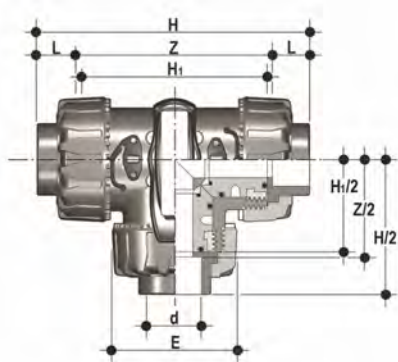

### LKDIV

DUAL BLOCK® 3-way ball valve with metric plain socket ends for solvent welding, L bore.

d	DN	PN	E	H	H <sub>1</sub>	L	Z	g	EPDM code	FKM code
16	10	16	54	118	80	14	90	310	LKDIV016E	LKDIV016F
20	15	16	54	118	80	16	86	310	LKDIV020E	LKDIV020F
25	20	16	65	145	100	19	107	550	LKDIV025E	LKDIV025F
32	25	16	73	160	110	22	116	790	LKDIV032E	LKDIV032F
40	32	16	86	188.5	131	26	136.5	1275	LKDIV040E	LKDIV040F
50	40	16	98	219	148	31	157	1660	LKDIV050E	LKDIV050F
63	50	16	122	266.5	179	38	190.5	2800	LKDIV063E	LKDIV063F

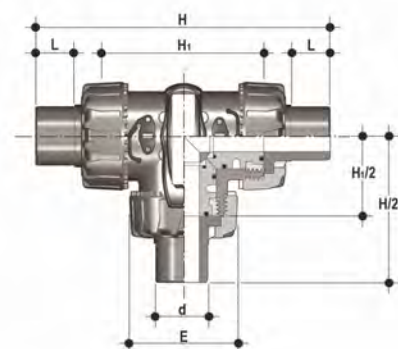

### TKDDV

DUAL BLOCK® 3-way ball valve with metric plain spigot ends for solvent welding, T bore.

d	DN	PN	E	H	H <sub>1</sub>	L	g	EPDM code	FKM code
20	15	16	54	140	80	16	320	TKDDV020E	TKDDV020F
25	20	16	65	175	100	19	565	TKDDV025E	TKDDV025F
32	25	16	73	188	110	22	810	TKDDV032E	TKDDV032F
40	32	16	86	220	131	26	1305	TKDDV040E	TKDDV040F
50	40	16	98	251	148	31	1700	TKDDV050E	TKDDV050F
63	50	16	122	294	179	38	2850	TKDDV063E	TKDDV063F



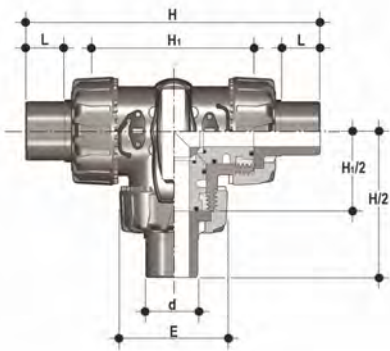

### LKDDV

DUAL BLOCK® 3-way ball valve with metric plain spigot ends for solvent welding, L bore

d	DN	PN	E	H	H <sub>1</sub>	L	g	EPDM code	FKM code
20	15	16	54	140	80	16	320	LKDDV020E	LKDDV020F
25	20	16	65	175	100	19	565	LKDDV025E	LKDDV025F
32	25	16	73	188	110	22	810	LKDDV032E	LKDDV032F
40	32	16	86	220	131	26	1305	LKDDV040E	LKDDV040F
50	40	16	98	251	148	31	1700	LKDDV050E	LKDDV050F
63	50	16	122	294	179	38	2850	LKDDV063E	LKDDV063F

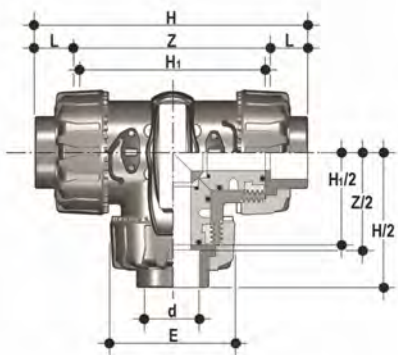

### TKDLV

DUAL BLOCK® 3-way ball valve with BS plain socket ends for solvent welding, T bore.

d	DN	PN	E	H	H <sub>1</sub>	L	Z	g	EPDM code	FKM code
3/8"	10	16	54	118	80	14.7	88.6	310	TKDLV038E	TKDLV038F
1/2"	15	16	54	118	80	17	85	310	TKDLV012E	TKDLV012F
3/4"	20	16	65	144.8	100	19	106.8	550	TKDLV034E	TKDLV034F
1"	25	16	73	160	110	22.5	115	790	TKDLV100E	TKDLV100F
1" 1/4	32	16	86	188.6	131	26	136.6	1275	TKDLV114E	TKDLV114F
1" 1/2	40	16	98	219.4	148	30.2	159	1660	TKDLV112E	TKDLV112F
2"	50	16	122	266.6	179	36.2	194.2	2800	TKDLV200E	TKDLV200F

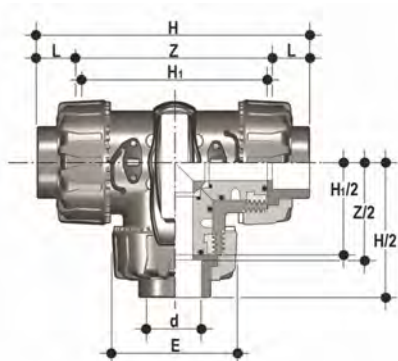

### LKDLV

DUAL BLOCK® 3-way ball valve with BS plain socket ends for solvent welding, L bore.

d	DN	PN	E	H	H <sub>1</sub>	L	Z	g	EPDM code	FKM code
3/8"	10	16	54	118	80	14.7	88.6	310	LKDLV038E	LKDLV038F
1/2"	15	16	54	118	80	17	85	310	LKDLV012E	LKDLV012F
3/4"	20	16	65	144.8	100	19	106.8	550	LKDLV034E	LKDLV034F
1"	25	16	73	160	110	22.5	115	790	LKDLV100E	LKDLV100F
1" 1/4	32	16	86	188.6	131	26	136.6	1275	LKDLV114E	LKDLV114F
1" 1/2	40	16	98	219.4	148	30.2	159	1660	LKDLV112E	LKDLV112F
2"	50	16	122	266.6	179	36.2	194.2	2800	LKDLV200E	LKDLV200F

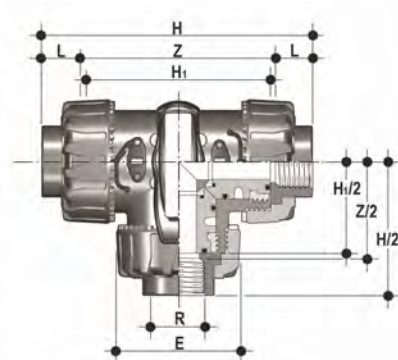

### TKDFV

DUAL BLOCK® 3-way ball valve with BS parallel socket threaded ends, T bore.

R	DN	PN	E	H	H <sub>1</sub>	L	Z	g	EPDM code	FKM code
3/8"	10	16	54	118	80	11.4	95	310	TKDFV038E	TKDFV038F
1/2"	15	16	54	125	80	15	95	310	TKDFV012E	TKDFV012F
3/4"	20	16	65	146	100	16.3	114	550	TKDFV034E	TKDFV034F
1"	25	16	73	166	110	19.1	129	790	TKDFV100E	TKDFV100F
1" 1/4	32	16	86	195.5	131	21.4	151	1275	TKDFV114E	TKDFV114F
1" 1/2	40	16	98	211	148	21.4	166	1660	TKDFV112E	TKDFV112F
2"	50	16	122	253.5	179	25.7	199	2800	TKDFV200E	TKDFV200F

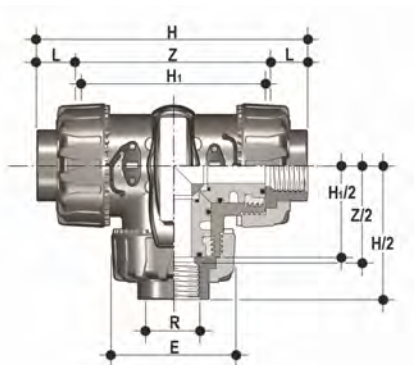

### LKDFV

DUAL BLOCK® 3-way ball valve with BS parallel socket threaded ends, L bore.

R	DN	PN	E	H	H <sub>1</sub>	L	Z	g	EPDM code	FKM code
3/8"	10	16	54	118	80	11.4	95	310	LKDFV038E	LKDFV038F
1/2"	15	16	54	125	80	15	95	310	LKDFV012E	LKDFV012F
3/4"	20	16	65	146	100	16.3	114	550	LKDFV034E	LKDFV034F
1"	25	16	73	166	110	19.1	129	790	LKDFV100E	LKDFV100F
1" 1/4	32	16	86	195.5	131	21.4	151	1275	LKDFV114E	LKDFV114F
1" 1/2	40	16	98	211	148	21.4	166	1660	LKDFV112E	LKDFV112F
2"	50	16	122	253.5	179	25.7	199	2800	LKDFV200E	LKDFV200F

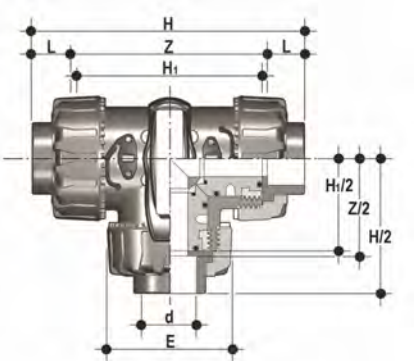

### TKDAV

DUAL BLOCK® 3-way ball valve with female ends for solvent welding, ASTM series, T-port ball.

d	DN	PN	E	H	H <sub>1</sub>	L	Z	g	EPDM code	FKM code
3/8"	10	16	54	132.2	80	19.5	93.2	310	TKDAV038E	TKDAV038F
1/2"	15	16	54	132.2	80	23	87.2	310	TKDAV012E	TKDAV012F
3/4"	20	16	65	159.2	100	25.5	108.2	550	TKDAV034E	TKDAV034F
1"	25	16	73	174	110	28.7	116.6	790	TKDAV100E	TKDAV100F
1" 1/4	32	16	86	205	131	32	141	1275	TKDAV114E	TKDAV114F
1" 1/2	40	16	98	227.6	148	35	157.6	1660	TKDAV112E	TKDAV112F
2"	50	16	122	267	179	38.2	190.6	2800	TKDAV200E	TKDAV200F

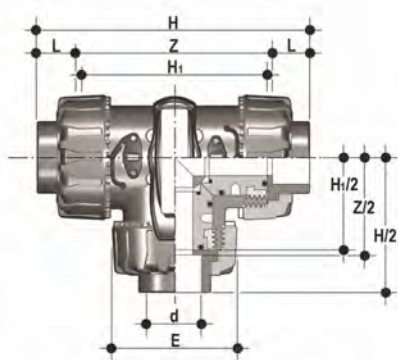

### LKDAV

DUAL BLOCK® 3-way ball valve with female ends for solvent welding, ASTM series, L-port ball.

d	DN	PN	E	H	H <sub>1</sub>	L	Z	g	EPDM code	FKM code
3/8"	10	16	54	132,2	80	19,5	93,2	310	LKDAV038E	LKDAV038F
1/2"	15	16	54	132,2	80	23	87,2	310	LKDAV012E	LKDAV012F
3/4"	20	16	65	159,2	100	25,5	108,2	550	LKDAV034E	LKDAV034F
1"	25	16	73	174	110	28,7	116,6	790	LKDAV100E	LKDAV100F
1" 1/4	32	16	86	205	131	32	141	1275	LKDAV114E	LKDAV114F
1" 1/2	40	16	98	227,6	148	35	157,6	1660	LKDAV112E	LKDAV112F
2"	50	16	122	267	179	38,2	190,6	2800	LKDAV200E	LKDAV200F

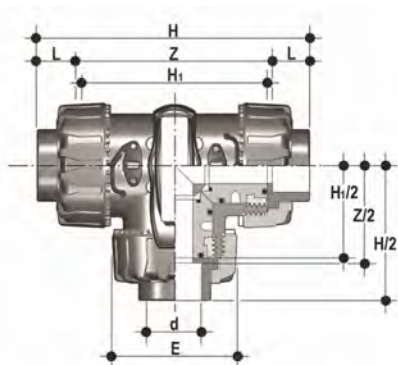

### TKDJV

DUAL BLOCK® 3-way ball valve with female ends for solvent welding, JIS series, T-port ball

d	DN	PN	E	H	H <sub>1</sub>	L	Z	g	EPDM code	FKM code
1/2"	15	16	54	146	80	30	86	310	TKDJV012E	TKDJV012F
3/4"	20	16	65	177	100	35	107	550	TKDJV034E	TKDJV034F
1"	25	16	73	196	110	40	116	790	TKDJV100E	TKDJV100F
1" 1/4	32	16	86	225	131	44	137	1275	TKDJV114E	TKDJV114F
1" 1/2	40	16	98	267,2	148	55	157,2	1660	TKDJV112E	TKDJV112F
2"	50	16	122	316	179	63	190	2800	TKDJV200E	TKDJV200F

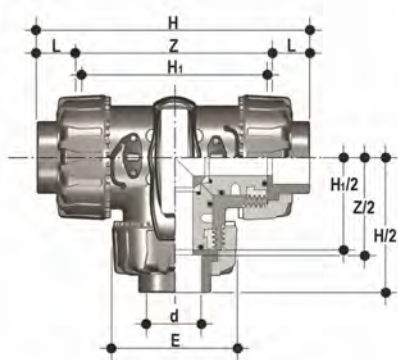

### LKDJV

DUAL BLOCK® 3-way ball valve with female ends for solvent welding, JIS series, L-port ball

d	DN	PN	E	H	H <sub>1</sub>	L	Z	g	EPDM code	FKM code
1/2"	15	16	54	146	80	30	86	310	LKDJV012E	LKDJV012F
3/4"	20	16	65	177	100	35	107	550	LKDJV034E	LKDJV034F
1"	25	16	73	196	110	40	116	790	LKDJV100E	LKDJV100F
1" 1/4	32	16	86	225	131	44	137	1275	LKDJV114E	LKDJV114F
1" 1/2	40	16	98	267.2	148	55	157.2	1660	LKDJV112E	LKDJV112F
2"	50	16	122	316	179	63	190	2800	LKDJV200E	LKDJV200F

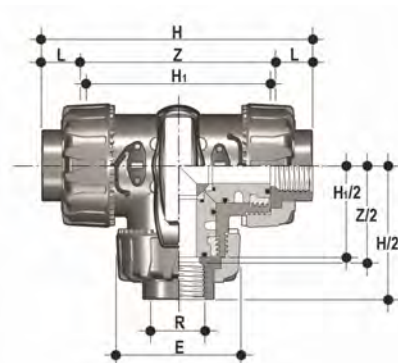

### TKDNV

DUAL BLOCK® 3-way ball valve with female ends, NPT thread, T-port ball.

R	DN	PN	E	H	H <sub>1</sub>	L	Z	g	EPDM code	FKM code
3/8"	10	16	54	118	80	13.7	90.6	310	TKDNV038E	TKDNV038F
1/2"	15	16	54	126	80	18	90.4	310	TKDNV012E	TKDNV012F
3/4"	20	16	65	146.4	100	18	110.4	550	TKDNV034E	TKDNV034F
1"	25	16	73	166.6	110	22.6	121.4	790	TKDNV100E	TKDNV100F
1" 1/4	32	16	86	195.8	131	25.1	145.6	1275	TKDNV114E	TKDNV114F
1" 1/2	40	16	98	211.4	148	24.7	162	1660	TKDNV112E	TKDNV112F
2"	50	16	122	253.8	179	29.6	194.6	2800	TKDNV200E	TKDNV200F

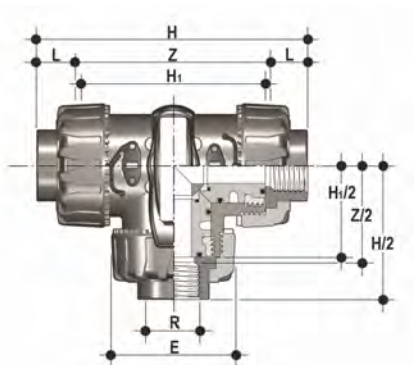

### LKDNV

DUAL BLOCK® 3-way ball valve with female ends, NPT thread, L-port ball.

R	DN	PN	E	H	H <sub>1</sub>	L	Z	g	EPDM code	FKM code
3/8"	10	16	54	118	80	13.7	90.6	310	LKDNV038E	LKDNV038F
1/2"	15	16	54	126	80	18	90.4	310	LKDNV012E	LKDNV012F
3/4"	20	16	65	146.4	100	18	110.4	550	LKDNV034E	LKDNV034F
1"	25	16	73	166.6	110	22.6	121.4	790	LKDNV100E	LKDNV100F
1" 1/4	32	16	86	195.8	131	25.1	145.6	1275	LKDNV114E	LKDNV114F
1" 1/2	40	16	98	211.4	148	24.7	162	1660	LKDNV112E	LKDNV112F
2"	50	16	122	253.8	179	29.6	194.6	2800	LKDNV200E	LKDNV200F

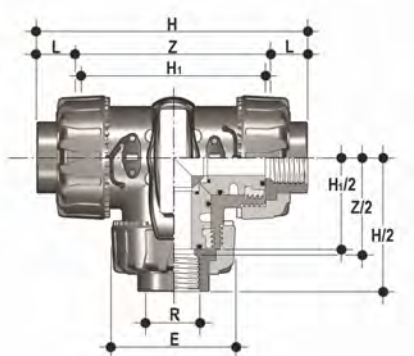

### TKDGV

DUAL BLOCK® 3-way ball valve with female ends, JIS thread, T-port ball

R	DN	PN	E	H	H <sub>1</sub>	L	Z	g	EPDM code	FKM code
1/2"	15	16	54	118	80	16	86	310	TKDGV012E	TKDGV012F
3/4"	20	16	65	144.8	100	19	106.8	550	TKDGV034E	TKDGV034F
1"	25	16	73	160	110	22	116	790	TKDGV100E	TKDGV100F
1" 1/4	32	16	86	188.6	131	25	138.6	1275	TKDGV114E	TKDGV114F
1" 1/2	40	16	98	219.4	148	26	167.4	1660	TKDGV112E	TKDGV112F
2"	50	16	122	266.6	179	31	204.6	2800	TKDGV200E	TKDGV200F

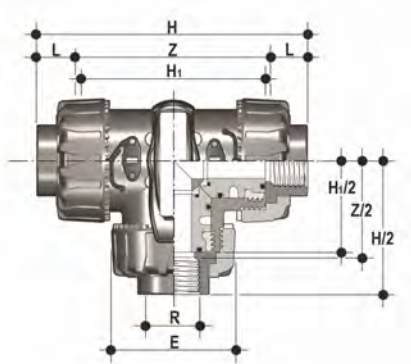

## LKDG V

DUAL BLOCK® 3-way ball valve with female ends, JIS thread, L-port ball

R	DN	PN	E	H	H <sub>1</sub>	L	Z	g	EPDM code	FKM code
1/2"	15	16	54	118	80	16	86	310	LKDG V012E	LKDG V012F
3/4"	20	16	65	144,8	100	19	106,8	550	LKDG V034E	LKDG V034F
1"	25	16	73	160	110	22	116	790	LKDG V100E	LKDG V100F
1" 1/4	32	16	86	188,6	131	25	138,6	1275	LKDG V114E	LKDG V114F
1" 1/2	40	16	98	219,4	148	26	167,4	1660	LKDG V112E	LKDG V112F
2"	50	16	122	266,6	179	31	204,6	2800	LKDG V200E	LKDG V200F

# ACCESSORIES

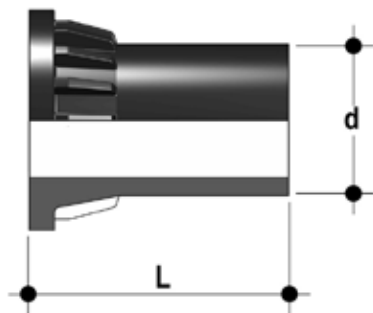

## CVDE

Long spigot PE100 end connectors for joints with electrofusion fittings or for butt welding

d	DN	PN	L	SDR	Code
20	15	16	55	11	CVDE11020
25	20	16	70	11	CVDE11025
32	25	16	74	11	CVDE11032
40	32	16	78	11	CVDE11040
50	40	16	84	11	CVDE11050
63	50	16	91	11	CVDE11063



## SHKD

Handle block kit 0° - 90° lockable

d	DN	Code
16 - 20	10 - 15	SHKD020
25 - 32	20 - 25	SHKD032
40 - 50	32 - 40	SHKD050
63	50	SHKD063





## LTKD

The LTKD stroke limiter specifically permits handle and ball rotation only at set opening and closing angles. The LTKD090 version permits operations for 90° angles while the LTKD180 version for 180° angles. The LTKD stroke limiter is made up of a single removable plate made of technopolymer. Designed for ISO 5211 bore and specifically designed to be directly housed on the valve body mounting flange. It is secured to the valve body by self-tapping screws or plastic rivets.

d	DN	90° code	180° code
16 - 20	10 - 15	LTKD090020	LTKD180020
25 - 32	20 - 25	LTKD090032	LTKD180032
40 - 50	32 - 40	LTKD090050	LTKD180050
63	50	LTKD090063	LTKD180063



## PSKD

Stem extension

d	DN	A	A <sub>1</sub>	A <sub>2</sub>	E	B	B <sub>1</sub>	B <sub>min</sub>	Code
16	10	32	25	32	54	70	29	139,5	PSKD020
20	15	32	25	32	54	70	29	139,5	PSKD020
25	20	32	25	40	65	89	34,5	164,5	PSKD025
32	25	32	25	40	73	93,5	39	169	PSKD032
40	32	40	32	50	86	110	46	200	PSKD040
50	40	40	32	50	98	116	52	206	PSKD050
63	50	40	32	59	122	122	62	225	PSKD063

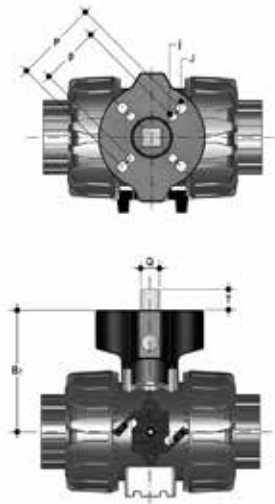

## Power Quick/CP

The valve can be equipped with pneumatic actuators, using the PP-GR module reproducing the drilling pattern foreseen by ISO 5211

d	DN	B <sub>2</sub>	Q	T	p x j	P x J	Code
16	10	58	11	12	F03 x 5,5	F04 x 5,5	PQCP020
20	15	58	11	12	F03 x 5,5	F04 x 5,5	PQCP020
25	20	69	11	12	*F03 x 5,5	F05 x 6,5	PQCP025
32	25	74	11	12	*F03 x 5,5	F05 x 6,5	PQCP032
40	32	91	14	16	F05 x 6,5	F07 x 8,5	PQCP040
50	40	97	14	16	F05 x 6,5	F07 x 8,5	PQCP050
63	50	114	14	16	F05 x 6,5	F07 x 8,5	PQCP063

\*F04 x 5.5 on request

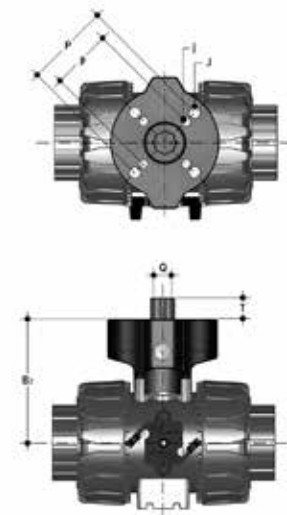

## Power Quick/CE

The valve can be equipped with electric actuators, using the PP-GR module reproducing the drilling pattern foreseen by ISO 5211

d	DN	B <sub>2</sub>	Q	T	p x j	P x J	Code
16	10	58	14	16	F03 x 5,5	F04 x 5,5	PQCE020
20	15	58	14	16	F03 x 5,5	F04 x 5,5	PQCE020
25	20	69	14	16	*F03 x 5,5	F05 x 6,5	PQCE025
32	25	74	14	16	*F03 x 5,5	F05 x 6,5	PQCE032
40	32	91	14	16	F05 x 6,5	F07 x 8,5	PQCE040
50	40	97	14	16	F05 x 6,5	F07 x 8,5	PQCE050
63	50	114	14	16	F05 x 6,5	F07 x 8,5	PQCE063

\*F04 x 5.5 on request

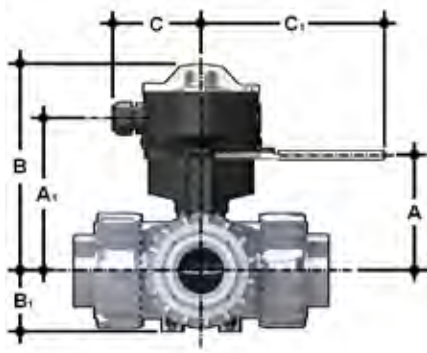

## LS Quick Kit

The Limit Switch Quick Kit allows the fast and secure installation of the FIP LSQT to the TKD valves. The body is in PP-GR and the handle is in stainless steel AISI 316. The handle block at 0° and 90° is also available by default (hole diameter 6.5 mm). The kit can be assembled on the valve even if already installed on the system. For technical data of the LSQT box see FIP actuated valves catalogue.

d	DN	A	A <sub>1</sub>	B	B <sub>1</sub>	C	C <sub>1</sub>	Code
16	10	60	91,5	137	29	76,5	157,5	LSQKIT20
20	15	60	91,5	137	29	76,5	157,5	LSQKIT20
25	20	71	102,5	148	34,5	76,5	157,5	LSQKIT25
32	25	76	107,5	153	39	76,5	157,5	LSQKIT32
40	32	93	124,5	170	46	76,5	157,5	LSQKIT40
50	40	99	130,5	176	52	76,5	157,5	LSQKIT50
63	50	116	147,5	193	62	76,5	157,5	LSQKIT63

# FASTENING AND SUPPORTING



All valves, whether manual or actuated, must be adequately supported in many applications.

The TKD valve series is therefore provided with an integrated bracket that permits direct anchoring of the valve body without the need of other components.

Using standard threaded nuts (not included) made of STAINLESS steel, you can anchor the valve on 4 fastening points.

d	DN	g	H	L	J
16	10	31,5	27	20	M5 x 8
20	15	31,5	27	20	M5 x 8
25	20	40	30	20	M5 x 8
32	25	40	30	20	M5 x 8
40	32	50	35	30	M6 x 10
50	40	50	35	30	M6 x 10
63	50	60	40	30	M6 x 10

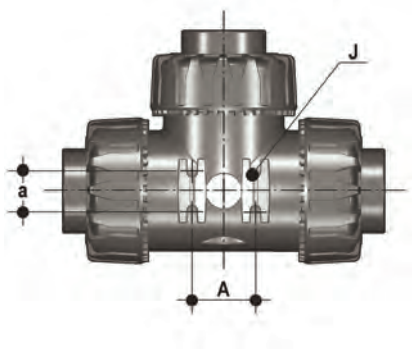

# COMPONENTS

## EXPLODED VIEW

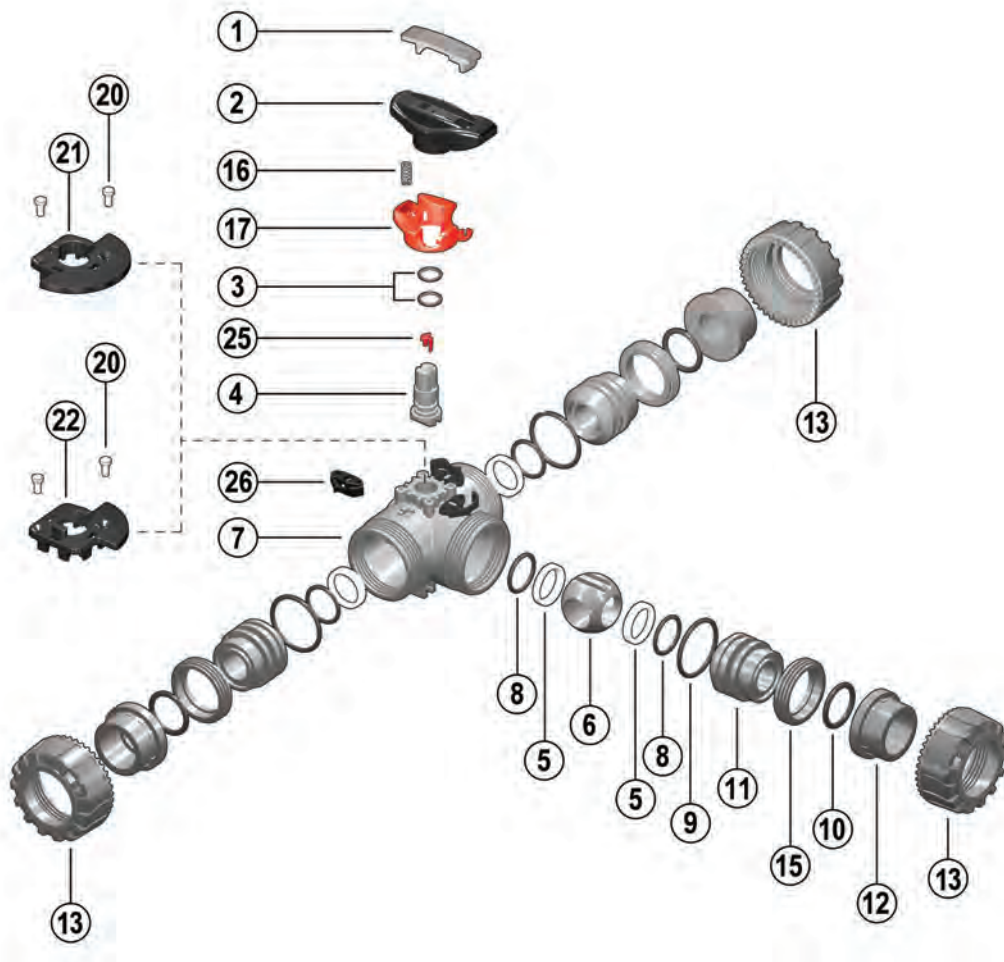

- |          |                                   |           |                                    |           |  |
|----------|-----------------------------------|-----------|------------------------------------|-----------|--|
| <b>1</b> | Handle insert (PVC-U - 1)         | <b>9</b>  | Radial seal O-Ring (EPDM-FKM - 3)  | <b>16</b> | Spring - SHKD accessory (STAINLESS steel - 1)**    |
| <b>2</b> | Handle (HIPVC - 1)                | <b>10</b> | Socket seal O-Ring (EPDM-FKM - 3)* | <b>17</b> | Safety handle block - SHKD accessory (PP-GR - 1)** |
| <b>3</b> | Stem O-ring (EPDM-FKM - 2)*       | <b>11</b> | Ball seat carrier (PVC-U - 3)      | <b>20</b> | Rivet for LTKD (POM - 2)**                         |
| <b>4</b> | Stem (PVC-U - 1)                  | <b>12</b> | End connector (PVC-U - 3)*         | <b>21</b> | LTKD 180° (POM - 1)**                              |
| <b>5</b> | Ball seat (PTFE - 4)*             | <b>13</b> | Union nut (PVC-U - 3)              | <b>22</b> | LTKD 90° (POM - 1)**                               |
| <b>6</b> | Ball (PVC-U - 1)                  | <b>15</b> | Threaded ring (PVC-U - 3)          | <b>25</b> | Position indicator (POM - 1)                       |
| <b>7</b> | Body (PVC-U - 1)                  |           |                                    | <b>26</b> | DUAL BLOCK® (POM - 3)                              |
| <b>8</b> | Ball seat O-Rings (EPDM-FKM - 4)* |           |                                    |           |  |

\* Spare parts

\*\* Accessories

The component material and quantity supplied are indicated in the parentheses.

## DISASSEMBLY

- 1) Isolate the valve from the line (release the pressure and empty the pipeline).
- 2) Unlock the union nuts by pressing the lever on the DUAL BLOCK® (26) along the axis and separate it from the union nut (fig. 1). It is also possible to completely remove the block device from the body of the valve.
- 3) Unscrew the union nuts (13) and extract the body (7).
- 4) After turning the handle (2) to the position with the three arrows pointing at the three ports (for L-port ball with two arrows facing the ports a and b), extract the insert (1) from the handle (2) and insert the two protrusions in the corresponding apertures in the threaded rings (15), extracting the carriers (11) by turning counterclockwise.
- 5) Extract the ball (6) from the central port being careful not to damage the seat surface.
- 6) Remove the PTFE ball seats (5) and O-Rings (8, 9, 10) from the carriers (11).
- 7) Pull the handle (2) upwards to remove it from the stem (4).
- 8) Press the stem (4) into the body and extract it.
- 9) Remove the PTFE ball seat (5) with relevant O-ring (8) from inside the valve body.
- 10) Remove the stem (4) O-rings (3) from their seats.

## ASSEMBLY

- 1) Insert the O-rings (3) on the stem (4).
- 2) Insert the O-ring (8) in the seat in the valve body and, next, the PTFE ball seat (5).
- 3) Insert the stem (4), from the interior, in the body, being sure the three marks on the socket correspond to the three outlets.
- 4) Insert the ball (6) from the central port b, being careful that the three bores match the three outlets (for L-port ball, the two bores must match the a and b outlets).
- 5) Insert the O-rings (8), PTFE ball seats (5), socket seal O-rings (10) and radial seal O-rings (9) in their seats on the carriers (11).
- 6) Insert the three carriers (11) with the relevant threaded rings (15), screwing in clockwise with the handle insert (1) and starting from the one on the central outlet b.
- 7) Press the handle (2) on the stem (4), being careful to match the printed arrows with the lines on the stem (fig. 2-3).
- 8) Return the insert (1) in the handle (2)
- 9) Insert the valve between the end connectors (12) and tighten the union nuts (13), making sure that the socket seal O-rings (10) do not exit their seats.



**Note:** during assembly operations, it is advisable to lubricate the rubber seals. Mineral oils are not recommended for this task as they react aggressively with EPDM rubber.

Fig. 1



Fig. 2



Fig. 3



Fig. 4



# INSTALLATION

Before proceeding with installation, please follow these instructions carefully:

- 1) Check that the pipes to be connected to the valve are aligned in order to avoid mechanical stress on the threaded joints.
- 2) Check that the DUAL BLOCK® union nut locking device (26) is fitted to the valve body.
- 3) To release the union nuts (13), axially press the release lever to separate the lock and then unscrew it in the counter-clockwise direction.
- 4) Unscrew the three union nuts (13) and insert them on the pipe segments.
- 5) Solvent weld or screw the end connectors (12) onto the pipe ends.
- 6) Position the valve body between the end connectors (12) and fully tighten the union nuts (13) manually by rotating clockwise, without using wrenches or other tools that could damage the union nut surface.
- 7) Lock the union nuts by returning the DUAL BLOCK® to its housing, pressing on it until the hinges lock on the union nuts.
- 8) If necessary, support the pipework with FIP pipe clips or by means of the carrier built-into the valve itself (see paragraph "fastening and supporting").

The TKD valve can be equipped with a handle lock to prevent ball rotation (available as an accessory). When the block (16, 17) is installed, lift the lever (17) and rotate the handle.

A padlock can also be installed on the handle to protect the system against tampering (fig. 4).  
Seals can be adjusted using the extractable insert on the handle (fig. 5-6). After positioning the ball as in figure 7-8, using this insert as a tool you can adjust the seals by screwing in the carriers following the indicated sequence (fig. 7-8).

A further fine-tuning of the seals can be done with the valve installed on the pipe by simply tightening the union nuts.

This "micro adjustment", only possible with FIP valves thanks to the patented "Seat stop system", allows the seal to be recovered where PTFE ball seats are worn due to a high number of operations.

## WARNINGS

Always avoid sudden closing manoeuvres and protect the valve from accidental operations.

Fig. 5



Fig. 6



Fig. 7

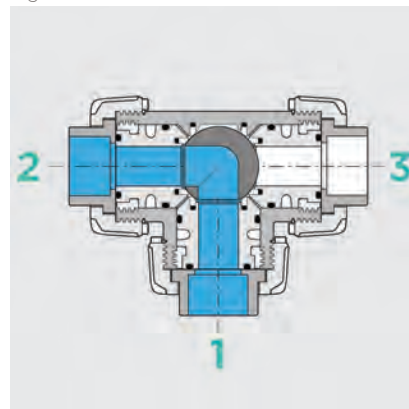

Fig. 8

