

USEFUL APPLICATIONS

- Shoemaking Machineries
- Glueing and binding machines (hot glue)
- Packaging and blister packing machines
- Paint booths
- T-shirt printing
- Climatic chambers and incubators
- Hot runner
- Glass bending ovens
- Extruders
- Industrial baking or large kitchens
- Continuous multi-zone ovens (for PCB, for leather goods, etc.)
- Ceramics ovens
- Heat-treatment ovens
- Ovens for goldsmiths and dentists
- Simple cascade controls
- Chillers

WITH WATTMETER FUNCTION AND INDEPENDENT TIMER

- INPUT FOR TC, RTD, PTC, NTC, MA OR V
- USER CALIBRATION
- H/C PID CONTROL WITH OVERSHOOT CONTROL, SELF-TUNE AND 2 AUTOTUNING ALGORITHMS
- 8 SEGMENT PROGRAMMER FUNCTION WITH SEGMENT RECOVERY, 2 EVENTS AND STASIS CONTROL (GUARANTEED SOAK)
- INDEPENDENT TIMER WITH 4 FUNCTIONING MODES
- H/C ON/OFF CONTROL WITH COMPRESSOR PROTECTION TIME
- WATTMETER FOR CALCULATING THE INSTANTANEOUS POWER AND ENERGY USED
- DIGITAL RETRANSMISSION OF THE SET POINT
- COUNTER FOR DAYS AND HOURS WORKED WITH PROGRAMMABLE THRESHOLD FOR PREVENTATIVE MAINTENANCE
- DELAY AT THE START UP FUNCTION
- PARAMETER SEQUENCE FREELY PROGRAMMABLE
- RAMP TO SET POINT CHANGE
- RS485 SERIAL COMMUNICATION WITH MODBUS RTU PROTOCOL
- SOFT START

TWO AUTOTUNING ALGORITHMS

IN ORDER TO MEET THE CLIENTS' NEEDS AND THOSE OF THEIR PRODUCTION PROCESSES, HAVE DEVELOPED TWO AUTOTUNING ALGORITHMS (AS WELL AS ADAPTIVE SELF-TUNING):

OSCILLATORY AUTOTUNING AND THE "FAST" TYPE.

- **OSCILLATORY AUTOTUNING** IS THE CLASSIC TYPE THAT REQUIRES 3 OSCILLATIONS TO BE MADE AROUND A SET POINT. THIS TYPE OF TUNING IS PARTICULARLY ACCURATE AND CAN BE SET UP AT ANY MOMENT. HOWEVER, IT TAKES A LONG TIME AND GENERATES AN OVERSHOOT THAT, ALTHOUGH NOT EXAGGERATED, MAY NOT BE APPRECIATED.

- **FAST AUTOTUNING** ON THE OTHER HAND IS MUCH FASTER AND THEREFORE PARTICULARLY SUITABLE FOR VERY SLOW PROCESSES. ANOTHER OF ITS CHARACTERISTICS IS THAT IT DOES NOT GENERATE OVERSHOOT (THE ALGORITHM AIMS AT KEEPING THE PV UNDER THE SET POINT). FINALLY FAST AUTOTUNING, APPLIED IN MULTI-LOOP SYSTEMS, FEELS THE "DRAGGING" EFFECTS PRODUCED BY NEIGHBOURING LOOPS MUCH LESS AND IS THEREFORE PARTICULARLY SUITABLE FOR MACHINES SUCH AS EXTRUDERS, HOT-RUNNERS, CONTINUOUS OVENS, ETC.

USER CALIBRATION

THIS FUNCTION ALLOWS THE MANUFACTURER OF THE MACHINE TO CALIBRATE THE ENTIRE MEASURING CHAIN THUS COMPENSATING FOR ALL ERRORS DUE

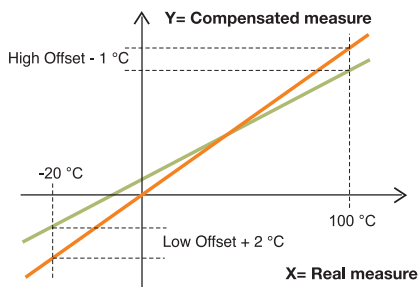

TO:

- SENSOR POSITION
- CLASS OF SENSOR
- ACCURACY OF THE INSTRUMENT.

THE USER CALIBRATION DOES NOT MODIFY THE PLANT CALIBRATION AND CAN ALWAYS BE CANCELLED.

DIGITAL RETRANSMISSION

BY MAKING USE OF SERIAL COMMUNICATION AND WITHOUT USING A PC, IT IS POSSIBLE FOR AN INSTRUMENT (MASTER) TO SEND ITS OPERATIVE SET POINTS TO OTHER INSTRUMENTS (SLAVE).

FURTHERMORE, EACH SLAVE INSTRUMENT CAN ADD ONE OF ITS OFFSETS TO THE VALUE RECEIVED.

IT IS THEREFORE POSSIBLE TO MODIFY THE SET POINT OF ALL THE CONNECTED INSTRUMENTS BY MODIFYING THE SET POINT OF THE MASTER ONLY. TYPICAL APPLICATIONS INCLUDE CONTINUOUS OVENS, HOT-RUNNERS, POLYMERIZATION OVENS, ETC.

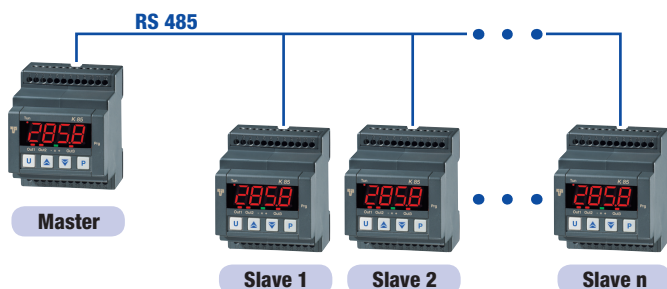

PROGRAMMER FUNCTION

APPLIED EXAMPLE:

PAINT BOOTH AND DRYING CHAMBER FOR SPRAY PAINTS (SPRAY BOOTHS FOR BODYWORK).

- DURING THE PAINTING PHASE, THE TEMPERATURE INSIDE THE BOOTH MUST REMAIN AT 20°C AND THE AIR USED FOR ITS VENTILATION MUST COME FROM OUTSIDE.
- ONCE THE PAINTING IS FINISHED, THE OPERATOR LEAVES THE BOOTH, CLOSES THE DOOR AND STARTS UP THE "DRYING" CYCLE. DURING THIS PHASE THE INSTRUMENT CLOSES THE AIR GATE AND RECYCLES THE AIR INSIDE THE BOOTH BY MEANS OF WHICH ENERGY CONSUMPTION IS REDUCED.

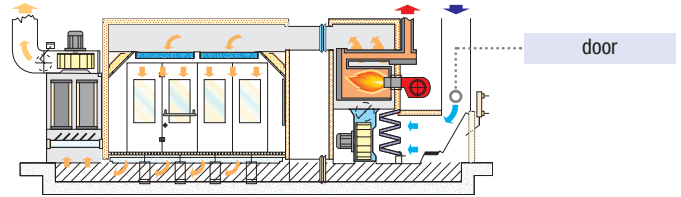

- WHEN THE DRYING PHASE IS OVER BUT BEFORE THE OPERATOR CAN ENTER THE BOOTH, IT IS NECESSARY TO RE-OPEN THE AIR GATE AND ENSURE THAT:
 - 1) THE AIR INSIDE THE BOOTH HAS BEEN REPLACED WITH AIR FROM OUTSIDE.
 - 2) THE TEMPERATURE IN THE CABIN IS LOWER THAN THE PRE-ESTABLISHED VALUE.

- THE THERMAL PROFILE NEEDED IS AS FOLLOWS.

OUT 1 = HEATING OUTPUT

OUT 2 = EVENT 1

OUT 3 = PROGRAMME RUNNING

EVENT 1 = IN ON DURING RAMP 1, STASIS 1, RAMP 2, AND STASIS 2.

ONCE THE PROGRAMME IS RUNNING THE DOOR STAYS BLOCKED.

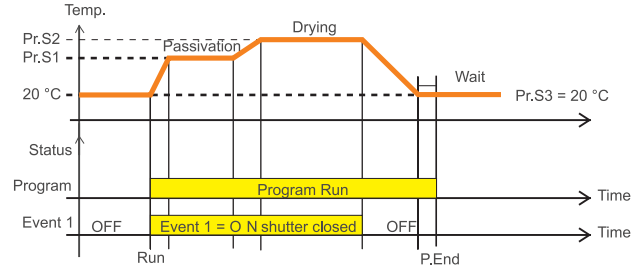

THE CONTROL FUNCTION OF THE STASIS ALLOWS US TO END THE PROGRAMME (THEREFORE ALLOWING ACCESS TO THE OPERATOR) ONLY WHEN THE TEMPERATURE IN THE BOOTH HAS REACHED THE PROGRAMMED VALUE (IN THE EXAMPLE Pr.S3). IN ADDITION, IF A POWER DOWN OCCURS DURING PROGRAM EXECUTION, AT THE NEXT POWER UP, THE INSTRUMENT IS ABLE TO CONTINUE THE PROGRAM EXECUTION STARTING FROM THE SEGMENT IN PROGRESS AND, IF THE SEGMENT WAS A SOAK, THE RESTART POINT WILL TAKE CARE OF THE SOAK TIME ALREADY MADE (WITH AN ACCURACY EQUAL TO 30 MIN.)

ACCESSORIES

A01 - PROGRAMMING KEY

MAKES IT POSSIBLE TO:

- MEMORIZE THE CONFIGURATION OF AN INSTRUMENT TO TRANSFER IT TO OTHER INSTRUMENTS
- TRANSFER A CONFIGURATION TO A PC
- MEMORIZE A CONFIGURATION RECORDED IN A PC
- LET THE INSTRUMENT "CONVERSE" DIRECTLY WITH A PC.



WinTec - SUPERVISOR

- DATA ACQUISITION
- SUPERVISION
- ALARM MANAGEMENT
- RECIPE MANAGEMENT
- TRENDS
- REPORTS

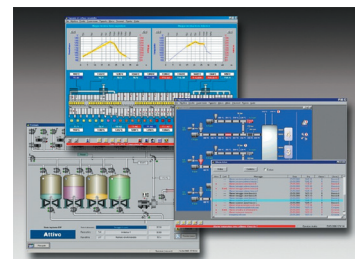

TECHNICAL FEATURES

ELECTRICAL DATA

POWER SUPPLY: SEE THE "HOW TO ORDER"

POWER CONSUMPTION: MAX 6 VA

DEVICE CLASS: CLASS II

NOMINAL PULSE VOLTAGE: 2,5 KV

CATEGORY OF OVERVOLTAGE: II

ISOLATION: REINFORCED BETWEEN LOW VOLTAGE (INPUT AND OUTPUT RELAY) AND FRONTAL PARTS. REINFORCED BETWEEN LOW VOLTAGE AND VERY LOW VOLTAGE PARTS (INPUT, STATIC OUTPUTS)

THERMOCOUPLE INPUT

TYPE: J,K,S,R,T PROGRAMMABLE

LINE RESISTANCE: 100 W WITH ERROR $\leq \pm 0.1\%$ OF THE INPUT RANGE WIDTH

UNIT OF MEASUREMENT: °C OR °F PROGRAMMABLE

COLD JUNCTION: AUTOMATIC COMPENSATION FROM 0 TO +50 °C

COLD JUNCTION ACCURACY: 0,1 °C/°C @ 25 °C AFTER A WARM-UP (INSTRUMENT SWITCH-ON) OF 20 MIN

CALIBRATION: ACCORDING TO EN 60584-1

BURN-OUT: AT THE END OF SCALE

TC Type	Range	Range
J	FROM 0 TO 1000 °C	FROM 32 TO 1832 °F
	FROM 0.0 TO 999.9°C	FROM 32.0 TO 999.0 °F
K	FROM 0 TO 1370 °C	FROM 32 TO 2498 °F
	FROM 0.0 TO 999.9°C	FROM 32.0 TO 999.0 °F
S	FROM 0 TO 1760 °C	FROM 32 TO 3200 °F
	FROM 0.0 TO 999.9°C	FROM 32.0 TO 999.0 °F
R	FROM 0 TO 1760 °C	FROM 32 TO 3200 °F
	FROM 0.0 TO 999.9°C	FROM 32.0 TO 999.0 °F
T	FROM 0 TO 400 °C	FROM 32 TO 752 °F
	FROM 0.0 TO 400.0°C	FROM 32.0 TO 752.0 °F

THERMORESISTANCE INPUT (RTD)

TYPE: PT 100 3 WIRES

CURRENT: 135 µA

LINE RESISTANCE: AUTOMATIC COMPENSATION UP TO 20 W/WIRE WITH MAXIMUM ERROR $\leq \pm 0.1\%$ OF THE INPUT SPAN

UNIT OF MEASUREMENT: °C OR °F PROGRAMMABLE

BURN-OUT: AT THE END OF SCALE

CALIBRATION: ACCORDING TO EN 60751/A2

RTD Type	Range	Range
Pt 100	FROM -200 TO 850 °C	FROM -328 TO 1562 °F
	FROM -200.0 TO 850.0 °C	FROM -328.0 TO 999.9 °F

THERMISTOR INPUT

TYPE: KTY 81-121 (990 W @ 25 °C) AND NTC 103AT-2 (10 K W @ 25 °C)

UNIT OF MEASUREMENT: °C OR F, PROGRAMMABLE

Type	Range	Range
KTY 81-121	FROM -55 TO 150 °C	FROM -67 TO 302°F
	FROM -55.0 TO 150.0 °C	FROM -67.0 TO 302.0 °F
NTC103 AT-2	FROM -50 TO 110 °C	FROM -58 TO 230°F
	FROM -50.0 TO 110.0 °C	FROM -58.0 TO 230.0 °F

LINEAR SIGNALS INPUT

TYPE: 0/10-50 mV, 0/12-60 mV, 0/4-20 mA, 0/1-5 V, 0/2-10 V

VISUALIZATION: PROGRAMMABLE FROM -1999 TO 9999

DECIMAL POINT: PROGRAMMABLE

BURN-OUT: (ONLY FOR ZERO SUPPRESSION SIGNALS) BURN-OUT SIGNALING WHEN THE INPUT SIGNAL IS LESS THAN 5% OF THE INPUT ·ELD

AUXILIARY SUPPLY FOR 0/4 - 20 mA TRANSMITTERS:

- TYPE: NOT ISOLATED AND NOT PROTECTED AGAINST SHORT-CIRCUIT

- LOAD: 10 V @ 20 M

INPUT IMPEDANCE:

- 51 W FOR mA INPU

- >1 M W FOR mV AND V INPUT

DIGITAL INPUTS

TYPE: FOR FREE-VOLTAGE CONTACTS

MAX CONTACT RESISTANCE: 10 W

CONTACT LOAD: 10 V, 6 MA

OUTPUTS

FUNCTION: PROGRAMMABLE

OUTPUT ACTION: DIRECT/REVERSE, PROGRAMMABLE

TYPE:

A) RELAY

CONTACT: SPDT OR SPST-NO

CONTACT LOAD: SEE THE "HOW TO ORDER"

RELAY ELECTRIC LIFE: 100000 OPERATIONS

B) LOGIC TENSION TO DRIVE A SOLID STAT

ISOLATION: OUTPUT **NOT** ISOLATED AS REGARDS THE VERY LOW VOLTAGE

PARTS

LOGIC STATE 1: 12 V $\pm 20\%$ @ 1 MA

10 V $\pm 20\%$ @ 20 MA

LOGIC STATE 0: <0.5 V

POWER OUTPUT SENSOR

ISOLATION: OUTPUT NOT ISOLATED AND NOT PROTECTED BY THE SHORT CIRCUIT

TENSION: 12 VDC

CURRENT: 20 mA MAX

COMMUNICATION

TYPE: TTL MODBUS AND RS 485 (OPTIONAL)

ISOLATION: FUNCTIONAL ISOLATION (50 V) WITH RESPECT TO THE VERY LOW VOLTAGE PARTS

PROTOCOL: MODBUS RTU

ELECTRICAL LEVELS: ACCORDING TO EIA STANDARDS

BAUD RATE: FROM 1200 TO 38000 BAUD

PARITY: NONE

DATA FORMED: 8 BIT + 1 START BIT + 1 STOP BIT

ENVIROMENTAL DATA

POLLUTION CATEGORY: 2

INSTALLATION CATEGORY: II

OPERATING TEMPERATURE: FROM 0 TO 50 °C

OPERATING HUMIDITY: < 95 RH% WITHOUT CONDENSATION

STORAGE TEMPERATURE: -25 °C TO 60 °C

FUNCTIONAL DATA

CONTROL: - SINGLE ACTION PID, DOUBLE ACTION PID

- ON/OFF, NEUTRAL

OVERALL ACCURACY: $\pm (0,5 \% \text{ SPAN} \pm 1 \text{ DIGIT @} 25 \text{ } ^\circ\text{C})$;

Tc S: $\pm (1 \% \text{ SPAN} \pm 1 \text{ DIGIT @} 25 \text{ } ^\circ\text{C})$

SAMPLING RATE: 130 MS

DISPLAY UPDATING TIME: 500 MS

COMMON-MODE REJECTION: 120 dB TO 50/60 Hz

NORMAL-MODE REJECTION: 60 dB TO 50/60 Hz

CONFORMITY: EMC 2004/108/CE (EN 61326) DIRECTIVE, LV 2006/95/CE (EN 61010-1) DIRECTIVE.

K 85

4 DIN MODULE - UP TO 3 OUTPUTS



K 85

MECHANICAL DATA

HOUSING: UL 94 V0 SELF-EXTINGUISHING PLASTIC
 MOUNTING: ON OMEGA DIN RAIL
 DIMENSIONS: 4 DIN MODULE, 70 X 84 MM, DEPTH 60 MM
 DISPLAY: 4 RED DIGIT H 12 MM
 WEIGHT: 180 G APPROX.
 TERMINAL BLOCK: 24 SCREW TERMINALS (SCREW M3 FOR CABLES FROM 0.25 TO 2.5 MM² OR FROM AWG 22 TO AWG 14)
 PROTECTION DEGREE: IP 40 (SCREW TERMINAL IP20) ACCORDING TO EN 60070-1 FOR INDOOR USE.

DIMENSIONS (mm)

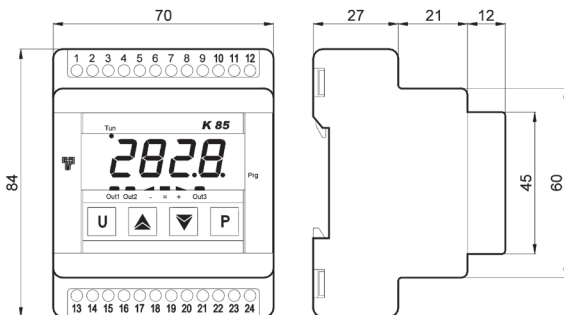

HOW TO ORDER

K85 = REGULATOR
 K85T = REGULATOR + TIMER
 K85P = REGULATOR + TIMER + PROGRAMMER

Power supply

L = 24 V AC/DC
 H = 100 - 240 V AC

Input

C = J, K, R, S, T, PT100, 0/12...60 mV
 E = J, K, R, S, T, PTC, NTC, 0/12...60mV
 I = 0/4...20 mA
 V = 0...1V, 0/1...5V, 0/2...10V

Out 1

R = SPDT 8 A RELAY (RESISTIVE)
 0 = VDC FOR SSR

Out 2

- NOT AVAILABLE
 R = SPDT 8 A RELAY (RESISTIVE)
 0 = VDC FOR SSR

Out 3

- NOT AVAILABLE
 R = SPST-NO 5 A RELAY (RESISTIVE)
 0 = VDC FOR SSR

Communication

- TTL ModBus
 S = RS 485 ModBus

Digital input

- NOT AVAILABLE
 D = 2 DIGITAL INPUTS

CONNECTIONS

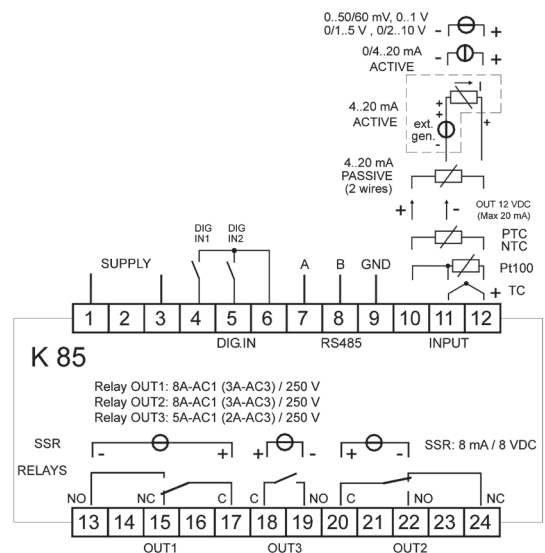

K 31-32

78 X 35 - UP TO 4 OUTPUTS

HOW TO ORDER

K31/ K32 (*) - = CONTROLLER
 K31/ K32 (*) T = CONTROLLER + TIMER
 K31/ K32 (*) P = CONTROLLER + TIMER + PROGRAMMER

(*) K32: Add the code **S** to have "Sensitive Touch" keyboard.

Power supply

F = 12 V AC/DC
 L = 24 V AC/DC (AVAILABLE SOON)
 H = 100 - 240 V AC/DC

Input

C = J, K, R, S, T, PT100, 0/12...60 mV + 2 DIGITAL INPUTS
 E = J, K, R, S, T, PTC, NTC, 0/12...60mV + 2 DIGITAL INPUTS
 I = 0/4...20 mA + 2 DIGITAL INPUTS
 V = 0...1V, 0/1...5V, 0/2...10V + 2 DIGITAL INPUTS

Out 1

R = SPDT 8 A RELAY (RESISTIVE)
 O = VDC FOR SSR

Out 2

- = NOT AVAILABLE
 R = SPDT 8 A RELAY (RESISTIVE)
 O = VDC FOR SSR

Out 3

- = NOT AVAILABLE
 R = SPST-NO 5 A RELAY (RESISTIVE)
 O = VDC FOR SSR

Out 4

- = NOT AVAILABLE
 R = SPST-NO 5 A RELAY (RESISTIVE)
 O = VDC FOR SSR

Communication

- = TTL ModBus
 S = RS 485 ModBus



K 31

SINGLE DISPLAY



K 32

DOUBLE DISPLAY



MECHANICAL DATA

HOUSING: UL 94 V0 SELF-EXTINGUISHING PLASTIC
 KEYBOARD: MECHANICAL AND "SENSITIVE TOUCH" TYPE (FOR K32 ONLY)
 MOUNTING: FLUSH IN PANEL
 DIMENSIONS: 78 X 35 MM, DEPTH 75,5 MM
 PANEL CUT-OUT: 71 (-0 TO + 0,6 MM) X 29 (-0 TO +0,5 MM)
 DISPLAY: K31 - 4 DIGIT SINGLE DISPLAY, RED COLOUR, H 12 MM + 3 LED BARGRAPH
 K32 - 4 DIGIT DOUBLE DISPLAY, RED AND GREEN COLOUR, H 7 MM
 WEIGHT: 180 G APPROX.
 SCREW TERMINALS: 24 SCREW TERMINALS (SCREW M3 FOR CABLES FROM 0.25 TO 2.5 MM² OR FROM AWG 22 TO AWG 14)
 PROTECTION DEGREE:
 - FRONT PROTECTION: IP 65 (WITH GASKET) ACCORDING TO EN 60070-1 FOR INDOOR USE
 - SCREW TERMINAL: IP20.

CONNECTIONS

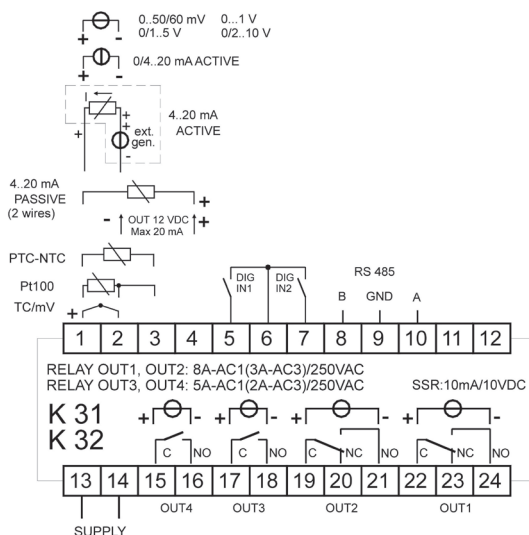

DIMENSIONS (mm)

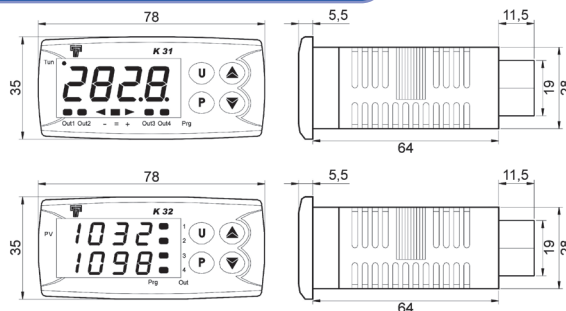

K SERIES

K 38-39

78 X 35 - UP TO 2 OUTPUTS



K 38

SINGLE DISPLAY



K 39

DOUBLE DISPLAY

MECHANICAL DATA

HOUSING: UL 94 V0 SELF-EXTINGUISHING PLASTIC

MOUNTING: FLUSH IN PANEL

DIMENSIONS: 75 X 33 MM, DEPTH 64 MM

PANEL CUT-OUT: 71 (-0 TO + 0,6 MM) X 29 (-0 TO +0,5 MM)

DISPLAY: K38 - 4 DIGIT SINGLE DISPLAY, RED COLOUR, H 12 MM + 3 LED BARGRAPH

K39 - 4 DIGIT DOUBLE DISPLAY, RED AND GREEN COLOUR, H 7 MM

WEIGHT: 180 G APPROX.

SCREW TERMINALS: 12 SCREW TERMINALS (SCREW M3 FOR CABLES FROM 0.25 TO 2.5 MM² OR FROM AWG 22 TO AWG 14)

PROTECTION DEGREE:

- FRONT PROTECTION: IP 65 (WITH GASKET) ACCORDING TO EN 60070-1 FOR INDOOR USE

- SCREW TERMINAL: IP20.

CONNECTIONS

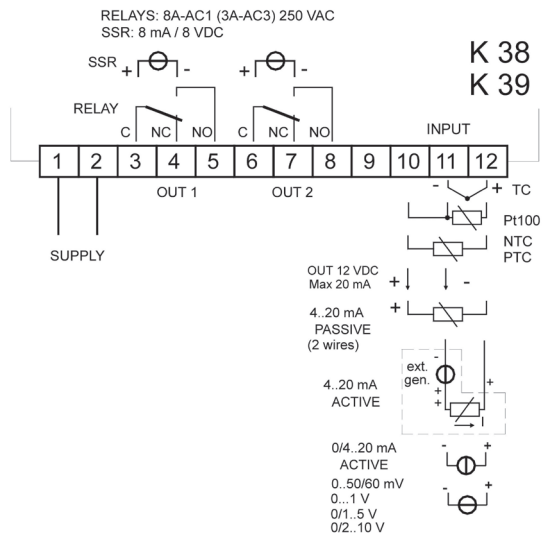

HOW TO ORDER

K38 - REGULATOR SINGLE DISPLAY

K38T = REGULATOR + TIMER

K38P = REGULATOR + TIMER + PROGRAMMER

K39 - REGULATOR DOUBLE DISPLAY

K39T = REGULATOR + TIMER

K39P = REGULATOR + TIMER + PROGRAMMER

Power supply

F = 12 V AC/DC

L = 24 V AC/DC

H = 100 - 240 V AC

Input

C = J, K, R, S, T, PT100, 0/12...60 mV

E = J, K, R, S, T, PTC, NTC, 0/12...60mV

I = 0/4...20 mA

V = 0...1V, 0/1...5V, 0/2...10V

Out 1

R = SPDT 8 A RELAY (RESISTIVE)

O = VDC FOR SSR

Out 2

- = NOT AVAILABLE

R = SPDT 8 A RELAY (RESISTIVE)

O = VDC FOR SSR

DIMENSIONS (mm)

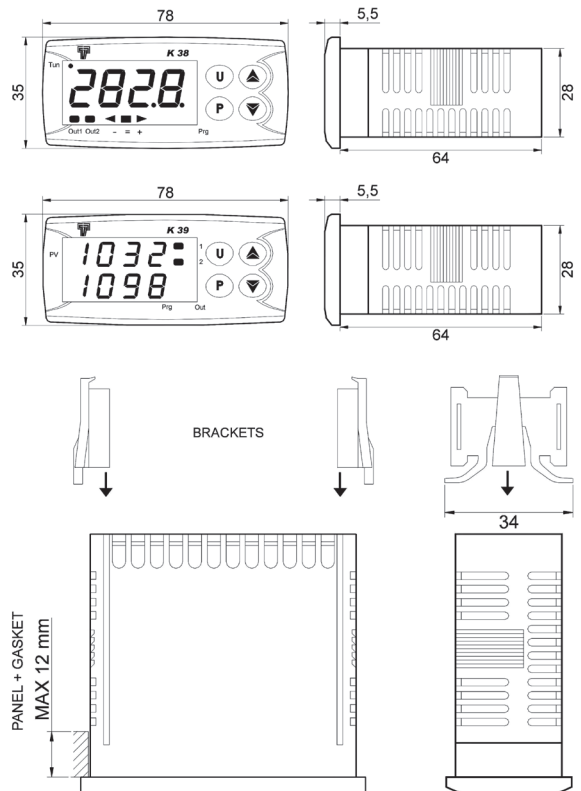

HOW TO ORDER

K48 - REGULATOR SINGLE DISPLAY
K48T = REGULATOR + TIMER
K48P = REGULATOR + TIMER + PROGRAMMER
K49 - REGULATOR DOUBLE DISPLAY
K49T = REGULATOR + TIMER
K49P = REGULATOR + TIMER + PROGRAMMER

Power supply

L = 24 V AC/DC
H = 100 - 240 V AC

Input

C = J, K, R, S, T, PT100, 0/12...60 mV
E = J, K, R, S, T, PTC, NTC, 0/12...60mV
I = 0/4...20 mA
V = 0...1V, 0/1...5V, 0/2...10V

Out 1

R = SPST-NO 8 A RELAY (RESISTIVE)
O = VDC FOR SSR

Out 2

- = NOT AVAILABLE
R = SPST-NO 8 A RELAY (RESISTIVE)
O = VDC FOR SSR

Out 3 / Digital inputs

- = NOT AVAILABLE
R = SPST 5 A RELAY (RESISTIVE)
O = VDC FOR SSR
D = 2 DIGITAL INPUTS

DIMENSIONS (mm)

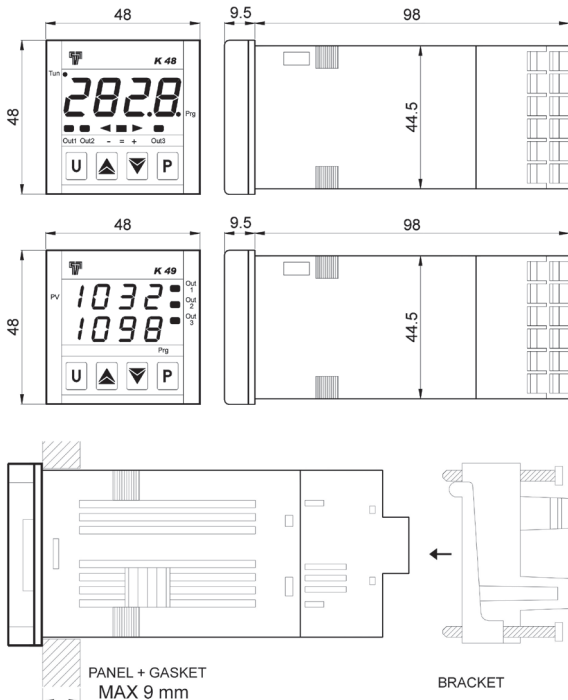

K 48-49

48 X 48 - UP TO 3 OUTPUTS



K 48
SINGLE DISPLAY

K 49
DOUBLE DISPLAY

MECHANICAL DATA

HOUSING: UL 94 V0 SELF-EXTINGUISHING PLASTIC

MOUNTING: FLUSH IN PANEL

DIMENSIONS: 48 X 48 MM (1/8 DIN), DEPTH 98 MM

PANEL CUT-OUT: 45 (-0 TO + 0,6 MM) X 45 (-0 TO +0,5 MM)

DISPLAY: K48 - 4 DIGIT SINGLE DISPLAY, RED COLOUR, H 12 MM + 3 LED BARGRAPH

K49 - 4 DIGIT DOUBLE DISPLAY, RED AND GREEN COLOUR, H 7 MM.

WEIGHT: 180 G APPROX.

SCREW TERMINALS: 12 SCREW TERMINALS (SCREW M3 FOR CABLES FROM 0.25 TO 2.5 MM² OR FROM AWG 22 TO AWG 14)

PROTECTION DEGREE:

- FRONT PROTECTION: IP 65 (WITH GASKET) ACCORDING TO EN 60070-1 FOR INDOOR USE

- SCREW TERMINAL: IP20.

CONNECTIONS

