

DN	1/4"	3/8"	1/2"	3/4"	1"	1"1/4	1"1/2	2"	2"1/2
S	76	76	82	90	106	120	142	165	194
S 1	38	38	41	45	53	60	71	82.5	97
Ø	10	10	10	15	20	25	32	40	50
P	18	18	17	18.5	20	23.5	28.5	32	35
H	50.5	50.5	50.5	53.5	63	67	73	80	90.5
E	8	8	8	8	10	10	12	12	12
Q	7/9/11	7/9/11	7/9/11	7/9/11	11/14	11/14	11/14	11/14	14
ISO	F03-05	F03-05	F03-05	F03-05	F05	F05	F05	F05	F05
*Nm	4	4	4	4	5	6	8	9	12
PN	40								

*: data effected without pressure

IN ACCORDING TO DIRECTIVE PED 2014/68/EU

Ref.	Composante	Matériau	Q.tà
1	Body	EN12420-CW617N-nickel	1
2	Ball	EN12165-CW617N-chromium plated	1
3	Seat	P.T.F.E. F391	4
4	Pushrod	EN12164-CW614N	1
5	O-Ring	NBR	4
6	Square	EN12164-CW614N	1
7	Sleeve	EN12420-CW617N-nickel	3
8	O-Ring	NBR	2
9	Motor plate disc	EN12420-CW617N-nickel	1
10	Antiscuff ring	P.T.F.E. F391	1
11	Nut	EN12164-CW614N	1
12	Nut	EN12164-CW614N	1
13	Antiscuff bush	P.T.F.E. F391	1

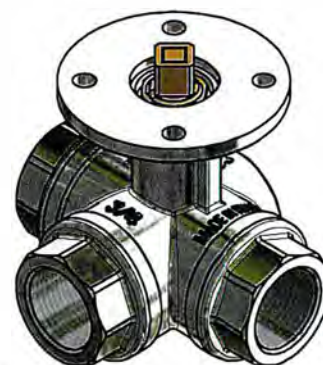

STANDARD VALVE FEATURES

- Working temperature : MIN. -10°C MAX. +100 °C
- Max pressure : 40 bar
- Threaded ends : ISO 228/1
- Motor plate disc: ISO 5211

SPECIAL EXECUTIONS ON REQUEST

O-Ring in : FP/EPDM/FKM/NBR
 Seats: PTFE+25% CARBOGRAPHITE/PTFE+25%GLASS

We don't assume the responsibility if you use products which are not consistent with the material used for the construction of our valves.
 To be used as a guide only, IDROSFER reserve the right to change these data without notice.

ASSEMBLY, USE AND MAINTENANCE INSTRUCTION

IN ACCORDING TO DIRECTIVE PED 2014/68/EU

EQUIPMENT PRESSURE DESCRIPTION: THREE-WAY BALL VALVE, WITH BRASS BODY FLOATING BALL

From DN 1/4" to DN 2 1/2"

DANGEROUS FLUIDS, GROUP 1, TAB. 6

USE

For the valves from DN 1/4" to DN 2"1/2 the intercepted fluids can be dangerous fluids of group 1 (including substances and mixtures as defined in Article 2, paragraphs 7 and 8 of Regulation EC no. 1272/2008, classified as dangerous in accordance with the classes of dangerous physical or health re. Annex I, parts 2 and 3 of that Regulation).

In addition, the intercepted fluids must be compatible with the materials used for the construction of the valves: brass, PTFE, PTFE reinforced with carbon graphite, FPM, EPDM, NBR, FKM.

In particular, comburent gases, gases under pressure (including compressed gases, liquefied gases, dissolved gases and refrigerated liquefied gases) and flammable liquids can be used.

Do not use unstable-self/reactive substances or mixtures (as defined in Regulation EC no. 1272/2008 § 2.8).

THE MAX PRESSURES IN ACCORDING TO THE WORKING TEMPERATURES ARE THE FOLLOWING:

* temperature °C	PN 40	Ball's tightness seats
* -10 °C ÷ 100 °C	40 bar	PTFE

*** MATERIAL RESISTENCE'S DATA**

WARNING!

IT IS USEFUL TO EMPTY THE BALL VALVE AND THE SYSTEM COMPLETELY WHEN THE INTERCEPTED FLUID COULD SOLIDIFY AT TEMPERATURES LOWER THAN 0°C (FOR EX., WATER) AND INCREASE ITS VOLUME DAMAGING ITS SEALING.

ASSEMBLY

Before installing make sure the pipe into which the valve is screwed does not show impurities that may damage the ball and the seat tightness causing leaking.

To seal the threadings use a dope compatible with the intercepted fluid without exceeding to avoid unuseful efforts when assembling.

After installing make sure the valve does not undergo stresses due to an exceeding anchorage distance or to unparallel pipes, then, support the pipes with the proper clamps.

The valve must be manoeuvred exclusively with the lever handle supplied with the kit without using any other supplementary lever handles.

Turn the lever handle by 90° clockwise to close the valve until it reaches its beat.

Turn the lever handle by 90° anticlockwise to open the valve until it reaches its beat.

The ball valve must always be fully open or fully closed.

Any intermediate position of the valve may cause long-lasting bucklings of the tightness seats which make the intercepted fluid leak.

To avoid water hammering on the pipes manoeuvre the valve by a gradual rotation.

When testing the systems never use pressures higher than the nominal pressure shown on the valves; that could buckle the seats and the gaskets and damage their sealing irremediably.

MAINTENANCE

Before take a valve apart, make sure that the pipe are not under pressure.

Every six months check the valve visually to verify there are no defects that may cause problems when using it and, if the case, replace it. Before acting on the valve make sure that the pipes are not under pressure.

We are not responsible in case of tampering of our valves without our authorization, in this case the warranty expires.

WASTE DISPOSAL

After replacement of the valve, it must be disposed according to the laws (about the waste disposal) of the Country of destination.

The waste (disused valve) can also be identified as recyclable material.

LIST OF INCOMPATIBLE SUBSTANCES

Many chemical substances react in a dangerous way when they come in touch with others.

Please find below a list of the main incompatible substances, by way of a non-limiting example.

Acetylene	with copper (piping), halogens, silver, mercury and their compounds
Acetone	with concentrated mixtures of sulphuric and nitric acid
Acetic acid	with chromic acid, nitric acid, hydroxyls, ethylene glycol, perchloric acid, peroxides and permanganates
Chromic acid	with acetic acid, naphthalene, camphor, alcohol, glycerol, turpentine and inflammable fluids
Nitric acid	with acetic, chromic and cyanogenic acid, aniline, carbon, hydrogen sulphide, fluids, gases and substances that are promptly nitrated
Oxalic acid	with silver and mercury
Perchloric acid	with acetic anhydride, bismuth and its alloys, alcohol, paper, wood, fats and other organic substances
Hydrogen sulphide	with nitric acid and oxidants.
Sulphuric acid	with chlorates, perchlorates, permanganates and water.
Alcohols and Polyols	with nitric acid.
Anhydrous ammonia	with mercury, halogens, calcium hypochlorite and hydrogen fluoride
Ammonium nitrate	with acids, metal powders, sulphur, combustible materials
Aniline	with nitric acid and hydrogen peroxide
Silver	with acetylene, oxalic acid, tartaric acid and ammoniac compounds
Arsenic (materials containing)	with any reducing agent
Azides	with water.
Chlorine dioxide	with ammonia, methane, phosphine, hydrogen sulphide
Bromine	with ammonia, acetylene, butadiene, butane, hydrogen, sodium carbide, turpentine and
Activated carbon	with all oxidizing agents, calcium hypochlorite
Cyanides	with acids and alkali
Chlorates	with ammonia salts, acids, metal powders, sulphur, finely pulverized organic and flammable compounds and carbon
Chlorine	with ammonia, acetylene, butadiene, petrol and other by-products of oil, hydrogen, sodium carbide, turpentine and finely pulverized metals
Chloroform	with sodium and potassium
Chlorides	with sulphuric acid
Dichloromethane	with sodium and potassium
Chlorine dioxide	with ammonia, methane, phosphine, hydrogen sulphide
Fluorine	with all other chemical substances
(White) phosphorus	with air, oxygen, alkali, reducing agents
Hydrocarbons in general	with fluorine, chlorine, formic acid, chromic acid, sodium peroxide
Hydrogen sulphate	with nitric acid vapours and oxidizing gasses
Iodine	with acetylene and ammonia
Hypochlorite	with acids, activated carbon
Flammable fluids	with ammonium nitrate, chromic acid, hydrogen peroxide, nitric acid, sodium peroxide and halogens
Mercury	with acetylene, fulminic acid, hydrogen
Alkaline metals (e.g. calcium, potassium, sodium)	with water, carbon dioxide, carbon tetrachloride, and other chlorinated hydrocarbons
Ammonium nitrate	with acids, metal powders, flammable fluids, chlorates, nitrates, sulphur and finely pulverized organic substances or flammable compounds
Nitrites and Nitrates	with acids
Nitroparaffin	with inorganic bases, amines
Calcium oxide	with water
Oxygen	with oils, fats, hydrogen, flammable fluids, solids and gasses
Phosphorus pentoxide	with water
Potassium perchlorate	with sulphuric acid and other acids.
Potassium permanganate	with glycerol, ethylene glycol, benzaldehyde and sulphuric acid
Hydrogen peroxide	with chromium, copper, iron, most other metals and their salts, flammable fluids and other combustible materials, aniline and nitromethane
Sodium peroxide	with any oxidizable substance, such as methanol, glacial acetic acid, acetic anhydride, benzaldehyde, carbon disulphide, glycerol, ethyl acetate and furfural.
Potassium	with carbon tetrachloride, carbon dioxide, water, chloroform, dichloromethane
Copper	with acetylene, azide and hydrogen peroxide
Sodium	with carbon tetrachloride, carbon dioxide, water, chloroform, dichloromethane
Sodium azide	with lead, copper and other metals. This compound is usually employed as a preservative, but it forms unstable and explosive compounds with metals
Selenium	with reducing agents
Sulphides	with strong acids
Carbon tetrachloride	Sodium, potassium